



## INSTALLATION

A bypass valve is to be installed in the outlet line as close as possible to the unit which is to be protected against excessively high pressure by the valve. No components liable to block the flow and prevent the valve from releasing liquid when the opening pressure has been attained may be installed in the return line from the valve. Overflowing liquid should be returned to tank enabling the heat evolved in overflowing to be distributed among the largest possible liquid volume. Bypass valve type GA may be mounted in any position. In order for the damping device incorporated in the valve to function satisfactorily, the valve must, however, be entirely filled with liquid. It is therefore appropriate for the valve to be fitted so that the liquid is not emptied out of it when it is no longer in action. The tightness of the system may not be hydrostatic pressure tested with water; this involves a risk of residual water which gives rise to corrosion damage and

may cause freezing damage when the valve is installed in outdoor plants during the winter season. A bypass valve may not be overloaded by connection to pumps or other units (eg accumulators, vertical weight loaded piston movements, etc.) which may evolve a larger volume of liquid than the specified maximum nominal volumetric flow for the valve. In the event of overcapacity, maintenance of pressure will be uncontrolled and a powerful lowering or raising of the pressure, depending on the circumstances, may result.

If long supply and return lines are connected to a bypass-valve, the result of controlling may be influenced by the frictional losses caused by the flow of the liquid in these lines. In accurate pressure control, it is therefore necessary for the diameter of the piping to be chosen in view of this. More detailed directions can be obtained from your IMO AB representative.

## TYPE SPECIFICATION

### Type GAR - valve with threaded pipe connections

Connection size	Ordering code			Nominal pressure setting range MPa	Max. nominal flow rate	
	Type	Size	Valve spring		l/s	l/min.
R 1/2"	GAR	012	T008	0.2 - 0.8	0.25	15
			T040	0.6 - 4.0	0.42	25
			T075	1.5 - 7.5	0.42	25
			T100	3.0 - 10	0.42	25
R 3/4"	GAR	034	T008	0.2 - 0.8	0.58	35
			T040	0.6 - 4.0	1.25	75
			T075	1.5 - 7.5	1.25	75
			T100	3.0 - 10	1.25	75
R 1"	GAR	100	T008	0.2 - 0.8	1.25	75
			T040	0.6 - 4.0	2.50	150
			T075	1.5 - 7.5	2.50	150
			T100	3.0 - 10	2.50	150
R 1 1/2"	GAR	112	T008	0.2 - 0.8	2.50	150
			T040	0.6 - 4.0	5.00	300
			T075	1.5 - 7.5	5.00	300
			T100	3.0 - 10	5.00	300

### Types GAS and GAD - valves with flanged pipe connections

Connection size	Ordering code			Nominal pressure setting range MPa	Max. nominal flow rate	
	Type	Size	Valve spring		l/s	l/min.
13 mm	GAS	015	T008	0.2 - 0.8	0.25	15
			T040	0.6 - 4.0	0.42	25
			T075	1.5 - 7.5	0.42	25
			T100	3.0 - 10	0.42	25
20 mm	GAS	020	T008	0.2 - 0.8	0.58	35
			T040	0.6 - 4.0	1.25	75
			T075	1.5 - 7.5	1.25	75
			T100	3.0 - 10	1.25	75
25 mm	GAS	025	T008	0.2 - 0.8	1.25	75
			T040	0.6 - 4.0	2.50	150
			T075	1.5 - 7.5	2.50	150
			T100	3.0 - 10	2.50	150
40 mm	GAS	040	T008	0.2 - 0.8	2.50	150
			T040	0.6 - 4.0	5.00	300
			T075	1.5 - 7.5	5.00	300
			T100	3.0 - 10	5.00	300
65 mm	GAD	065*	T008	0.2 - 0.8	7.50	450
			T040	0.6 - 4.0	15.0	900
			T075	1.5 - 7.5	15.0	900
			T100	3.0 - 10	15.0	900

\* Valve GAD 06501 is identical to the valve previously designated GAD 60 mm S7B.

**Recommended set pressure:** 10 % above system working pressure.

**Viscosity range:** 2 - 400 mm<sup>2</sup>/s

**Temperature range:** - 20 °C to + 90 °C (with O-rings of Nitrile rubber)

- 20 °C to + 150 °C (with O-rings in Viton)

# DIMENSIONS FOR VALVE TYPES GAR, GAS AND GAD

Dimensions in mm

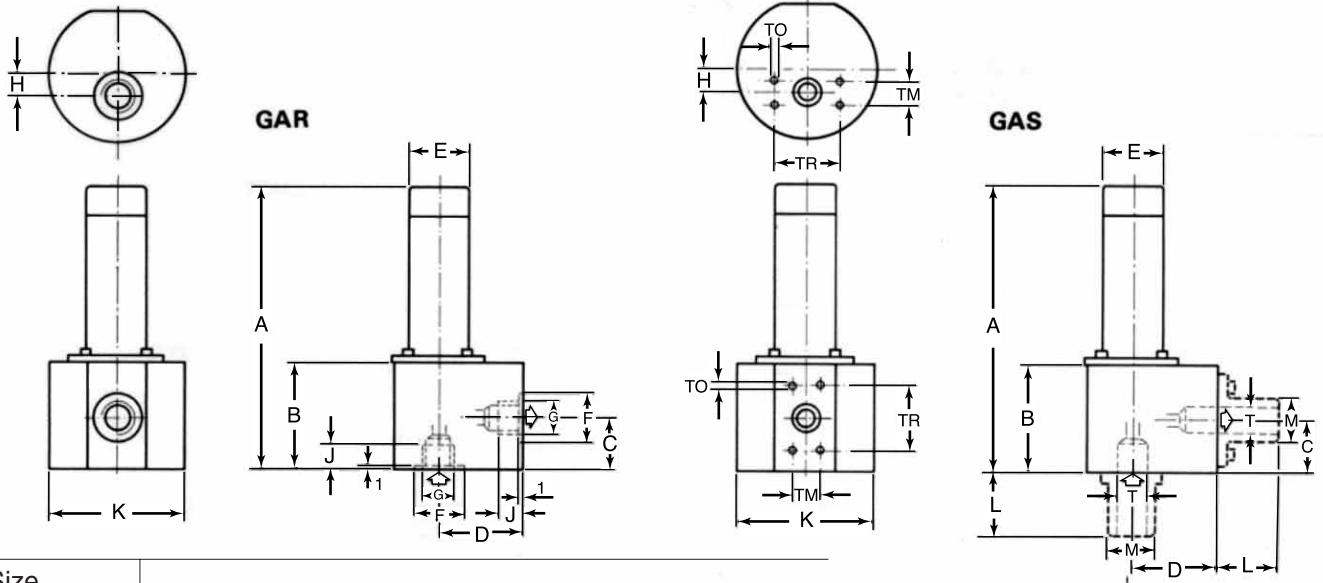

Size					
GAR	012	034	100	112	—
GAS	015	020	025	040	—
GAD	—	—	—	—	65
Connection diameter					
GAR G	R 1 1/2"	R 3/4"	R 1"	R 1 1/2"	—
GAS T	13	20	25	40	—
GAD	—	—	—	—	65
Size counter-flange for GAS					
	1/2"	3/4"	1"	1 1/2"	—
A	172	214	259	373	
B	66	80	96	136	
C	33	40	45	63	
D	58*	64*	79	107	
E	45	45	58	80	
F	29	36	44	60	
H	17	17.5	23	29.5	
J	14	17	18	22	
K	90	103	74**	100**	
L	40	40	45	50	
M	19	27	38	50	
TM	17.2	22.4	26.2	35.8	
TO	M8	M10	M10	M12	
Depth	15	23	23	27	
TR	38	47.8	52.4	69.8	
Weight, kg approx	3.9	6.0	8.8	20	45

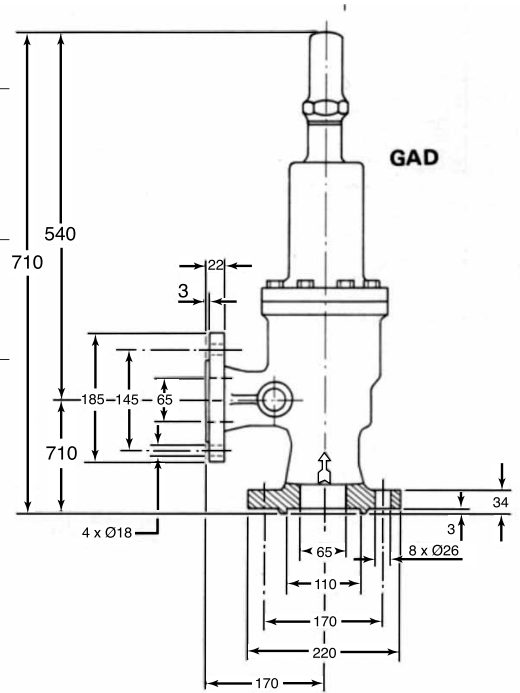

Flanges according to DIN 2548 (pressure side) and DIN 2543 (delivery side)  
 Counter-flanges according to DIN 2637/2513 (pressure side) and DIN 2633 (delivery side)  
 Installation dimensions according to DIN 3202

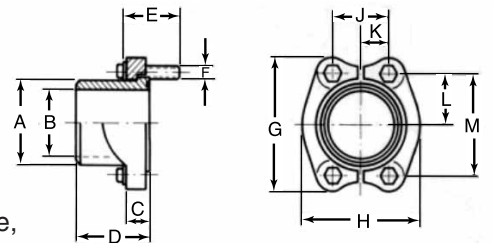

## DIMENSIONS - COUNTERFLANGES FOR GAS

Counterflange for welded pipe connection incorporating pipe weld nipple, O-ring, split SAE J518 flange and retaining bolts – bolts of steel in strength class ISO 8.8 with minimum length E.

Flange Size	Article No.	A	B	C	D	E	F	G	H	J	K	L	M
1/2"	136226	19	13	13	40	25	M10	55	46	17.2	8.6	19	38
3/4"	136234	27	20	14	40	35	M10	66	52	22.4	11.2	23.9	47.8
1"	140715	38	25	16	45	35	M10	70	59	26.2	13.1	26.2	52.4
1 1/2"	130997	50	40	16	50	40	M 12	94	84	35.8	17.9	34.9	69.8

## SELECTION DIAGRAM

The curves show approximations of the valve characteristics set upon delivery at maximum nominally adjustable opening pressure with valve springs T008, T040, T075 and T100 respectively. The pressure rise (accumulation) will not be more than 10% above the set pressure but will have a minimum value of 0.2 MPa.

