

Maintenance and Service Instruction

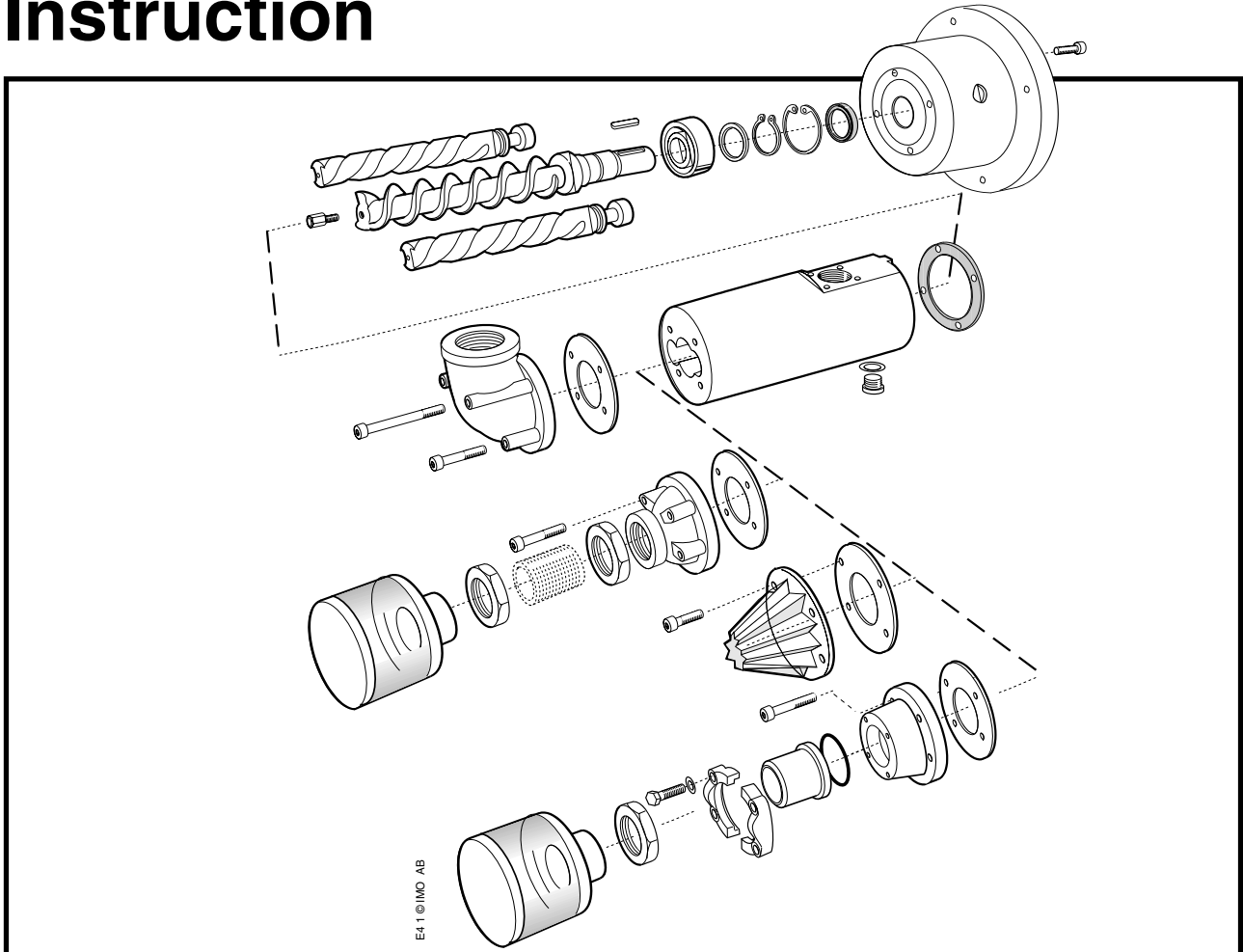

This instruction is valid for all E4 pump models shown on page 2

Contents	Page
List of components	2
Exploded view/Ordering code	3
Service intervals	4
Inspection of shaft seal, rotors, O-rings, ballbearing	4
Sectional view	5
List of tools/Dismantling	6
Reassembly	9



Before commencing any work, read this instruction carefully!
Failure to comply with these instructions may cause damage and personal injury!

For more information about the pumps identification code, technical data and performance we refer to the E4 Product description.

For more information about the pumps installation, start-up and trouble shooting we refer to the Imo Installation and Start-up instruction for medium and high pressure pumps.

List of components

Valid for all E4 pumps, size 025-070. Rotor lead and Generation: K1, N1, L1, K4, N4, L4

With version codes:

L } Y }	E } R } V }	B } J } T }	E }
------------	-------------------	-------------------	-----

The version code is composed of the letters in the 4 columns. Also valid for pump options A101, A141.

Example of pump designations std: E4 025L4 LRBE

Pos No	Denomination	Qty	Spare parts set:				Re- marks
			G031 Bearing element	G050 Radial seal	G055 Joint kit	G102 Pump element	
102	Power rotor	1				x	1
113	Key	1				x	
122	Ball bearing	1	x			x	
124	Retaining ring	1	x			x	
124A	Support washer	1	x			x	
202	Idler rotor	2				x	1
382	Screw	4					
401	Pump body	1				x	
423	O-ring	1					5
427	Split flange	2					5
427A	Weld stud	1					5
428	Screw	4					5
428A	Washer	4					5
451	Screw	4					
451A	Washer	4					
453	Screw	2/4					3
453A	Washer	4					7
455	Screw	2					4
463	Plug	1				x	
463A	T-ring	1					
489	Strainer	1					8
489A	Distance ring	1					2
491	Nut	1/2					6
501	Connecting frame	1					
506	Gasket	1			x		
509	Radial seal	1		x			
514	Retaining ring	1				x	
551	Inlet chamber	1					7
556	Gasket	1			x		7

Remarks

1. CCW-rotation version pos no 101, 201
2. Valid for xxTE sizes 045
3. Valid for xxBE: 2 pieces and xxJE 4 pieces
4. Valid for xxBE
5. Valid for xxJE sizes 052-070
6. Valid for xxJE sizes 025-045: 2 pieces and sizes 052-060: 1 piece.
7. Valid for xxJE and xxBE
8. Valid for xxTE and xxJE

Exploded view

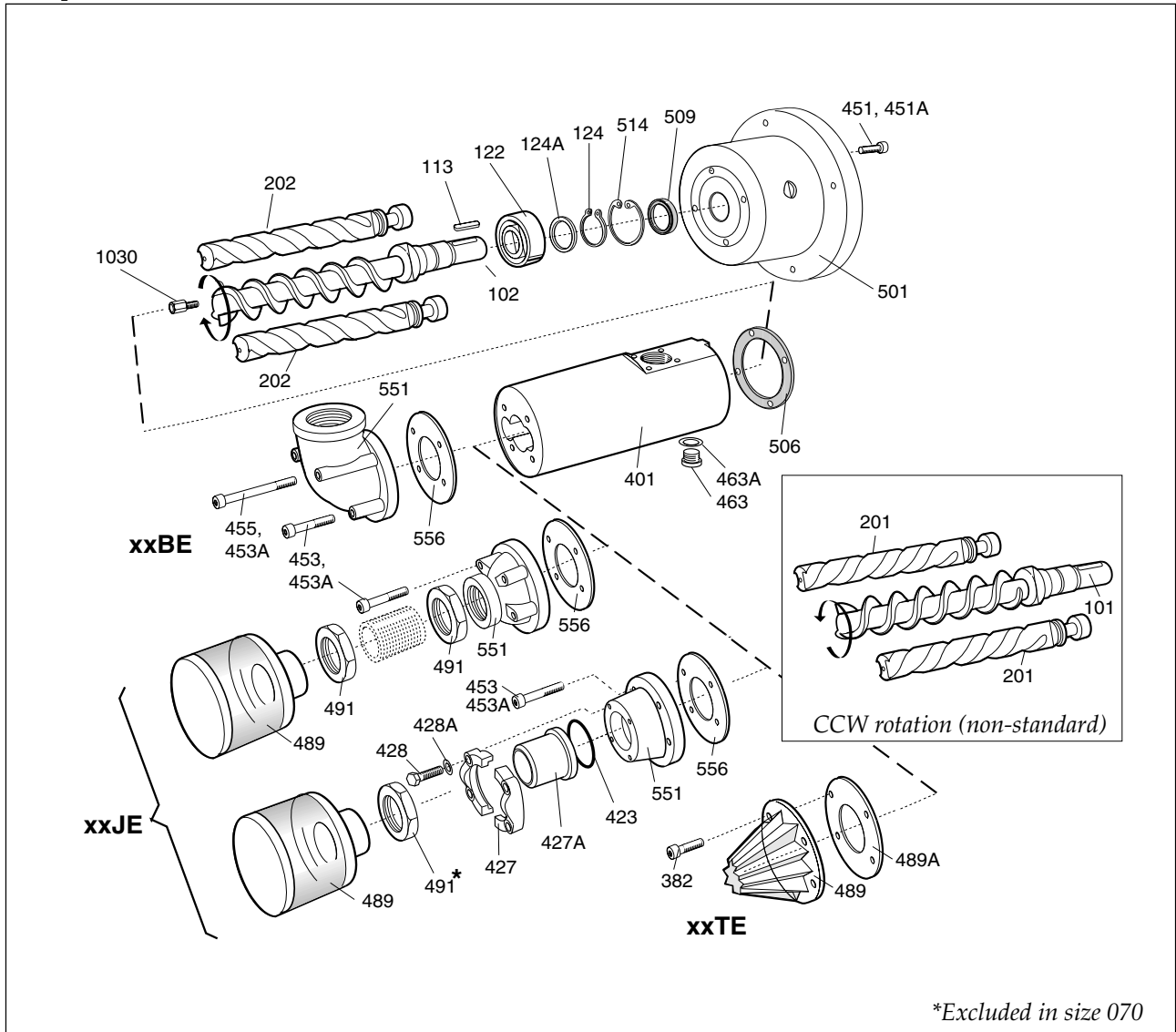

Fig. 1

Ordering code

Pos no	Spare part sets	Part numbers, sizes						
		025	032	038	045	052	060	070
G102	<i>Pump element CW rotation</i>							
	Normal lead - pump N1	140483	140509	140525	140541	140566	141051	141077
	Low-lead - pump K1	-	-	140533	140558	140574	141069	141085
	" - pump L1	140491	140517	-	-	-	-	-
G031	Bearing element	144170	144170	144188	144188	144188	144196	144204
G050	Radial seal							
	Version code xRxx	128009	128009	107680	107680	107680	107680	107680
	" xVxx	188840	188840	173690	173690	173690	173690	173690
G055	Joint kit	144212	144212	144212	144220	144238	144246	144253

Recommendation

Every shut down for service of a plant is costly. The time for repair should therefore be limited to a minimum, which can be accomplished by keeping a spare pump. The changed pump can later be repaired and then become the spare pump.

Spare part sets:

G055 Joint kit: for dismantling of the pump.

Pump element: for repair after damage or greater wear.

Service intervals

The intervals for inspection and replacement of wear parts vary greatly with the properties of the pumped liquid and can only be determined by experience.

All internal parts of the E4-pump are lubricated by the pumped liquid. Pumping a liquid which contains abrasive materials, or a liquid that is corrosive, will significantly reduce service life and call for shorter service intervals.

Wear in the pump may be indicated by:

- Vibration
- Noise
- Loss of capacity
- Reduction in flow/pressure
- Leakage

We recommend planned inspection and overhaul at regular intervals, not exceeding 3 years.

Inspection of shaft seal

An external visual inspection of the pump is advisable at least every two days to assure that the shaft seal is not leaking too much. Ten drops per hour can be considered as acceptable.

Excessively leaking shaft seals should be changed without delay.

Inspection of rotors

If the pump is not able to maintain the pressure, dismantle the rotor set by following the instructions at page 6-9.

Internal clearances in the pump, which are vital for its proper function, may have been affected by wear. Acceptable wear can be determined only by experience of the actual application. As a rule of thumb the following max clearance values may apply:

- Between rotor and bores or bushings: 0.2 mm
- Between rotor flanks: 0.2 mm

For light duties (low pressure, medium viscosity) even bigger clearances may be acceptable whilst for low viscosity/high pressure duties the limit will be lower.

Also check if there are major scratches on these parts. If needed replace the entire pump unit or reassemble by following the instructions at page 9-11.

O-rings

All O-rings found to be hard or damaged shall be replaced.



If the pumps operating temperature exceeds 60°C let the pump cool off before any service, maintenance or dismantling work is commenced to avoid burn injury.



All work carried out on the pump has to be performed in such a manner that risks for personal injury are observed!



When handling liquids that may harm skin use gloves and/or protective clothing.



When handling liquids which may involve fire hazards appropriate precautions to avoid danger are to be taken.



In case of failure for a system with elevated pressure, fluid jets may cause injury and/or damage.



Oil leakage may make the floor slippery and cause personal injury.

Service for ball bearing

The ball bearing may be damaged if hit by a sledgehammer or anything alike. Clean the ball bearing with white spirit when dismantled.



Before any maintenance work, ensure that the driver is deenergized and the pump hydraulically isolated.



Connecting and disconnecting of electric cables must be done only by personnel authorized to do such work.

Sectional view

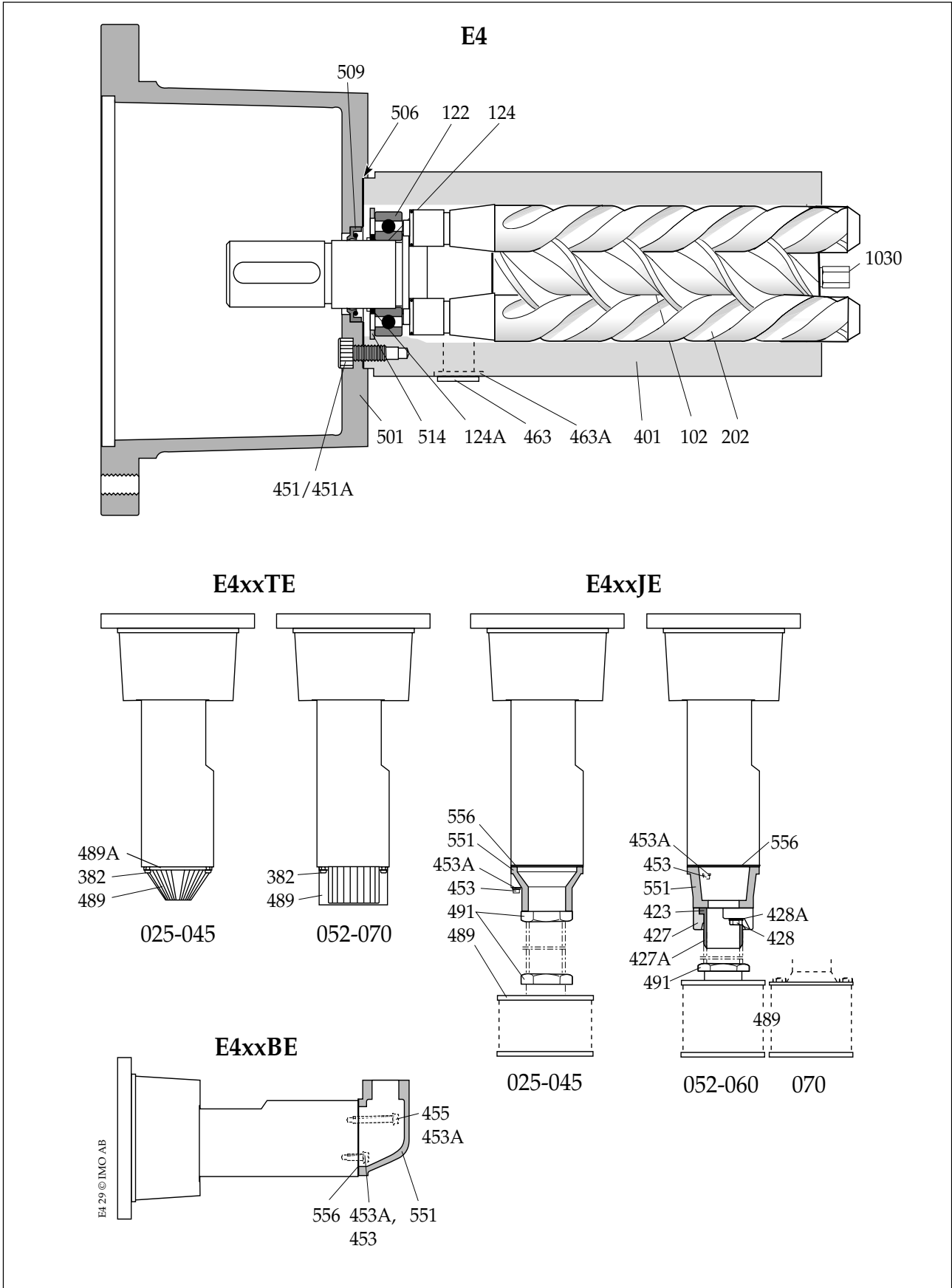

Fig. 2

List of tools necessary for dismantling/reassembly

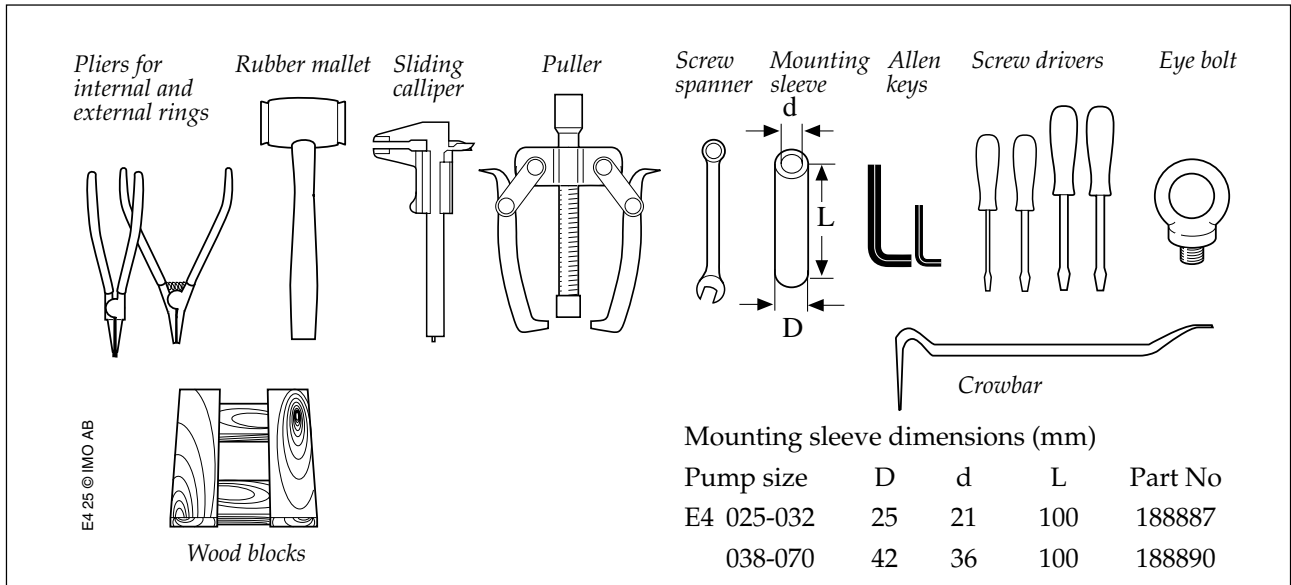

Fig. 3

Dismantling

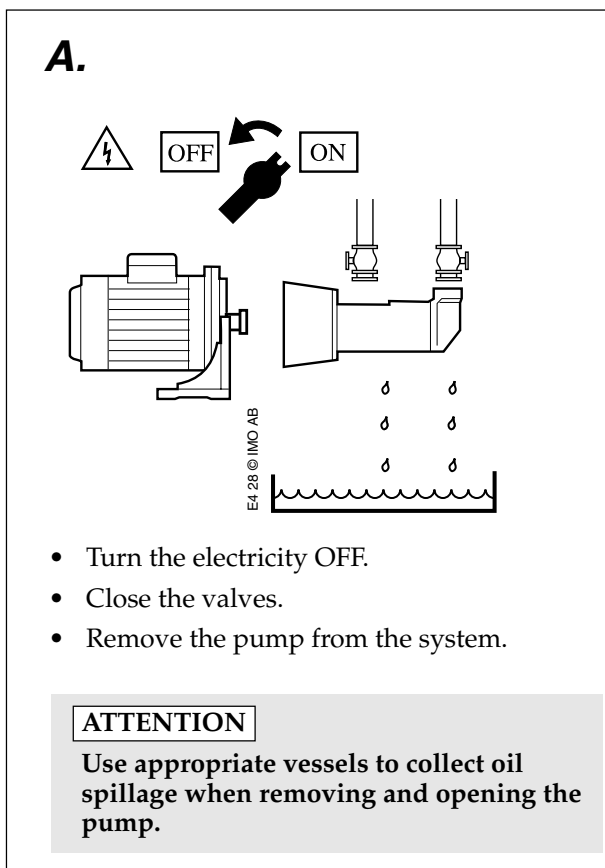

Fig. 4

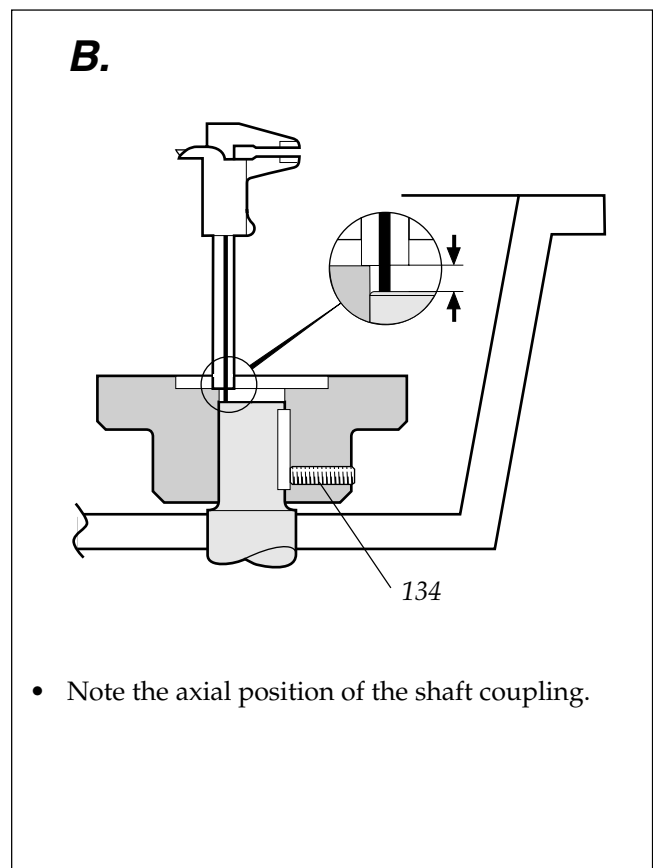
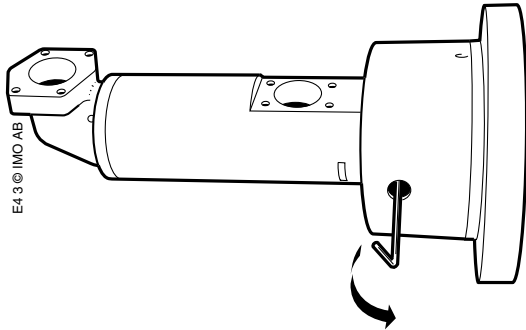

Fig. 5

C.



- Untighten the locking screw 134.

D.

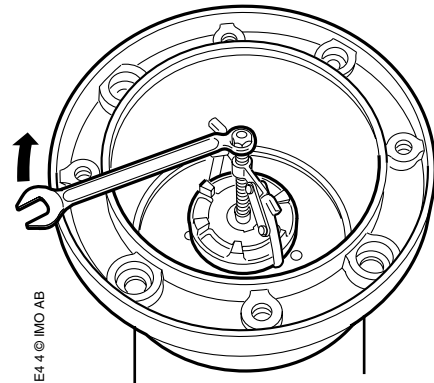

- Remove the shaft coupling, if necessary use a puller.

Fig. 6

Fig. 7

E.

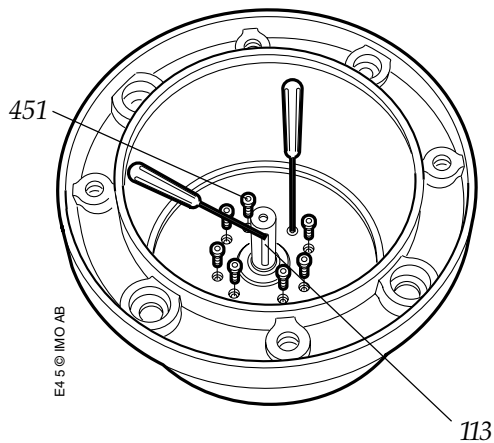

- Remove the key 113.
- Remove the screws 451.

F.

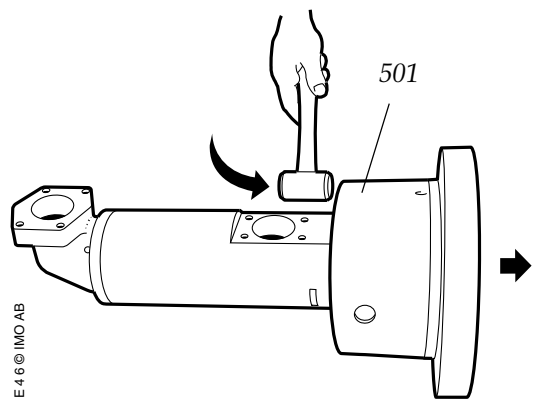

- Knock lightly on the connecting frame 501 and remove it.

Fig. 8

Fig. 9

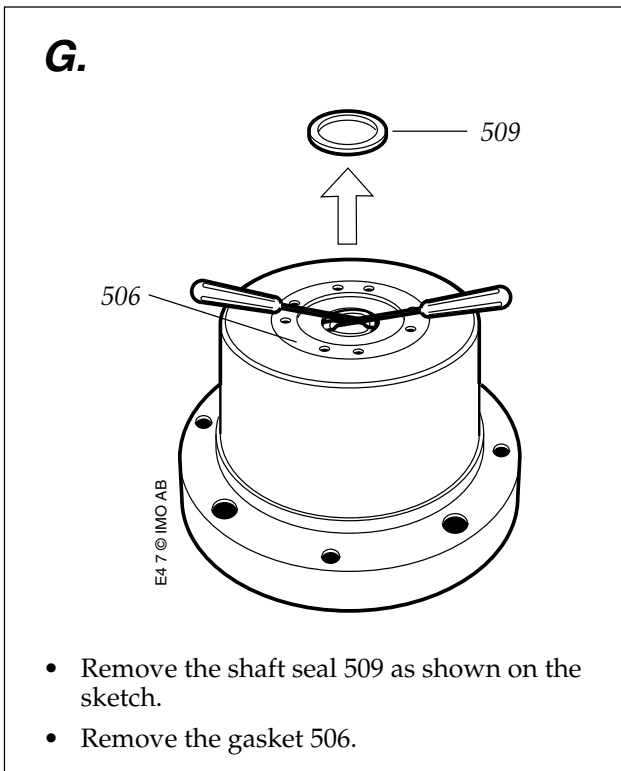

Fig. 10

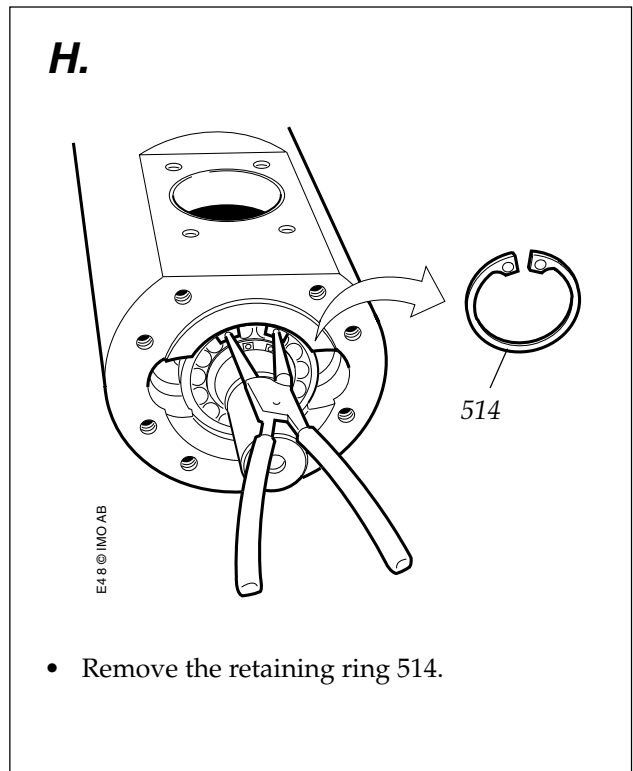

Fig. 11

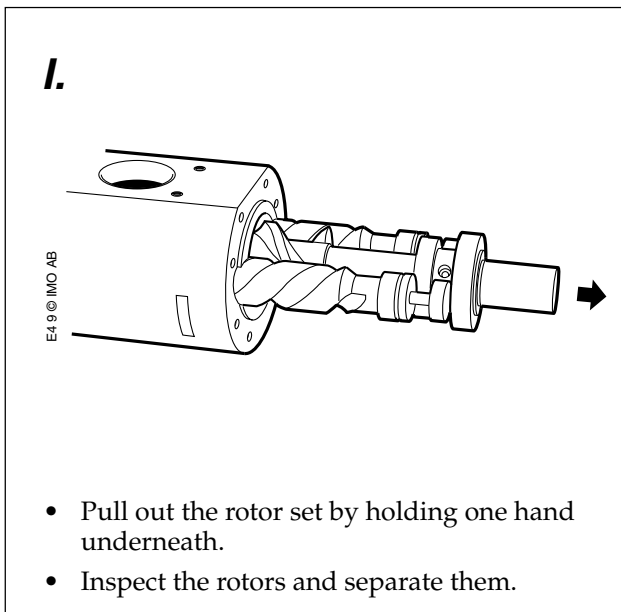

Fig. 12

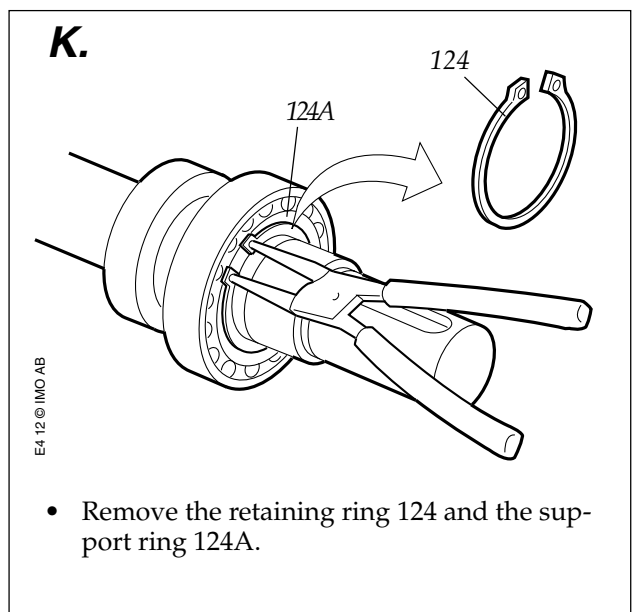

Fig. 13

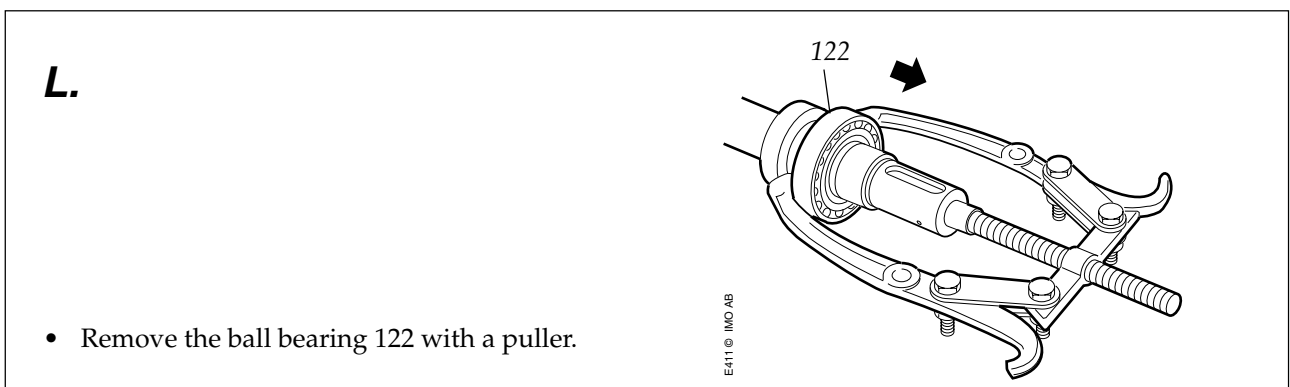

Fig. 14

Reassembly

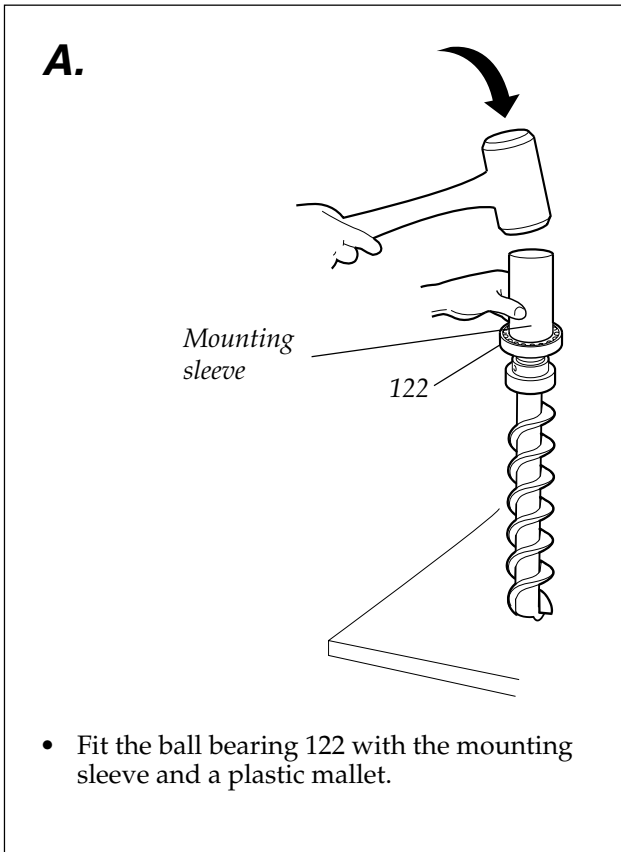

Fig. 15

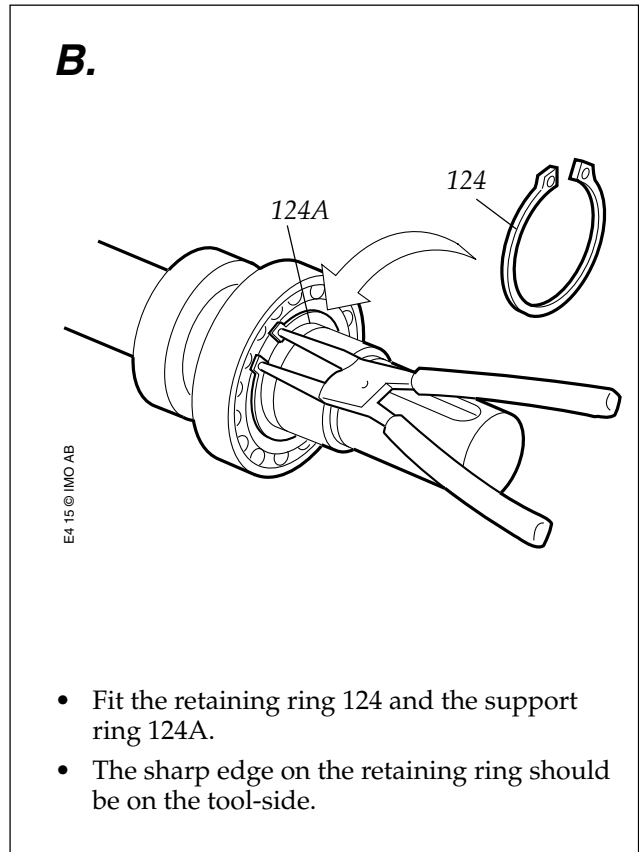

Fig. 16

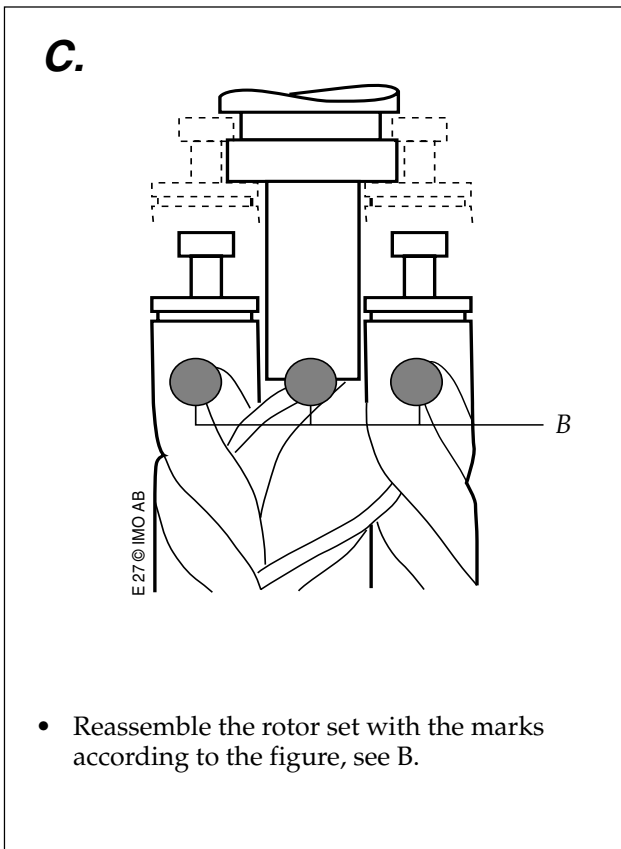

Fig. 17

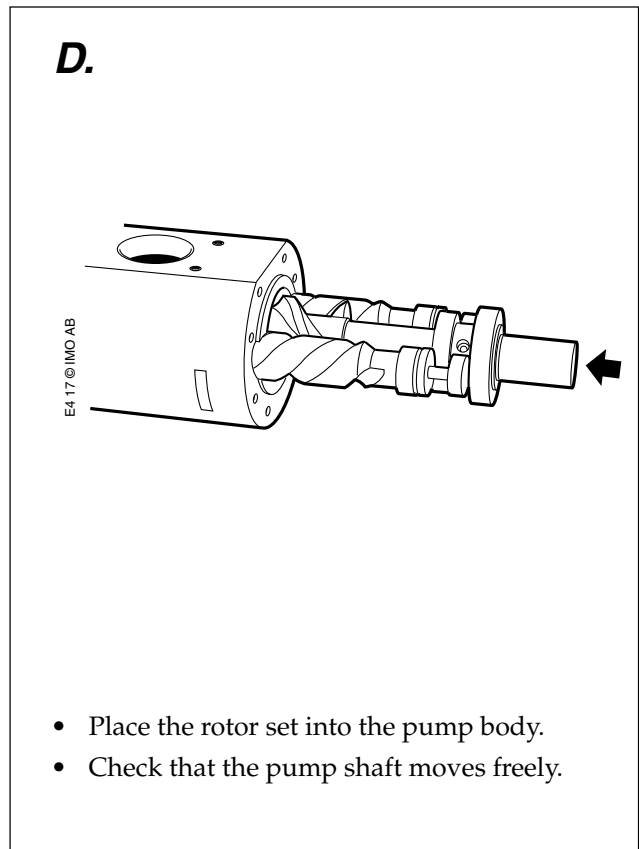

Fig. 18

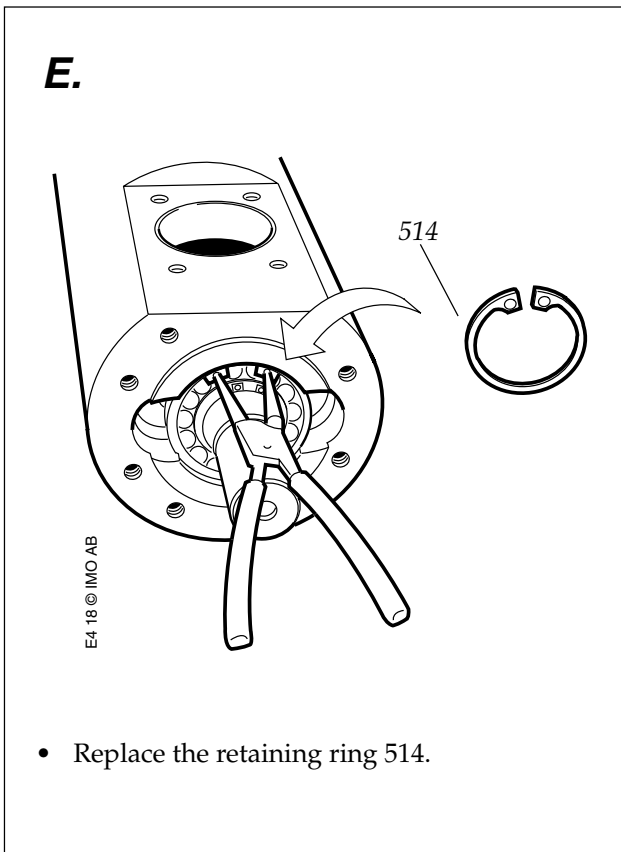

Fig. 19

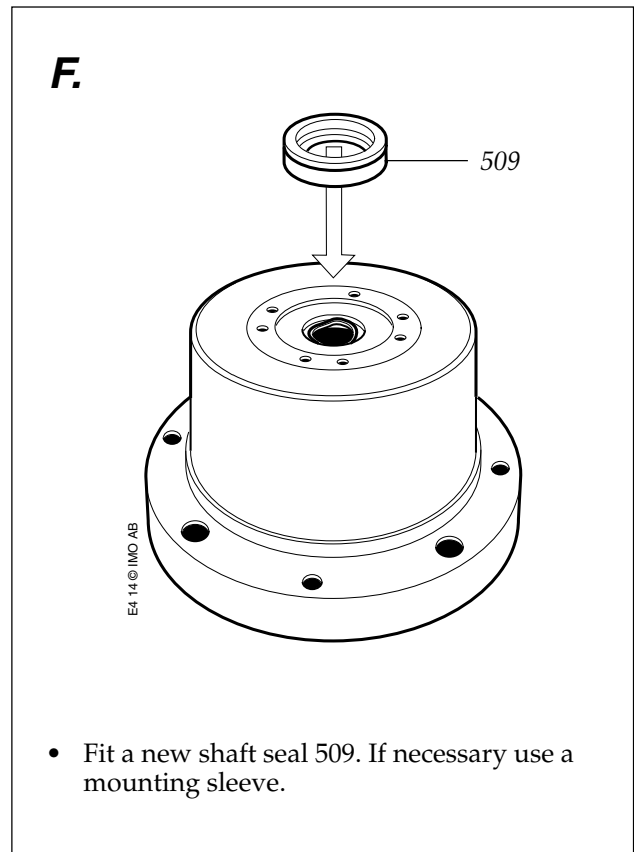

Fig. 20

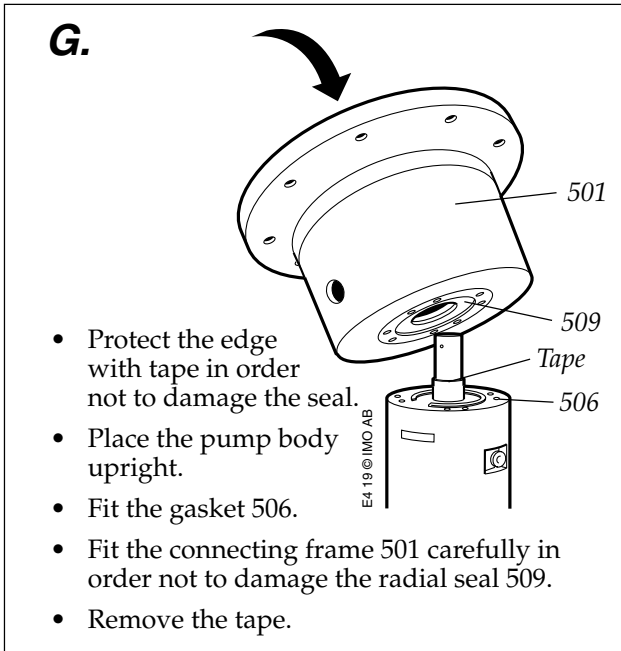

Fig. 21

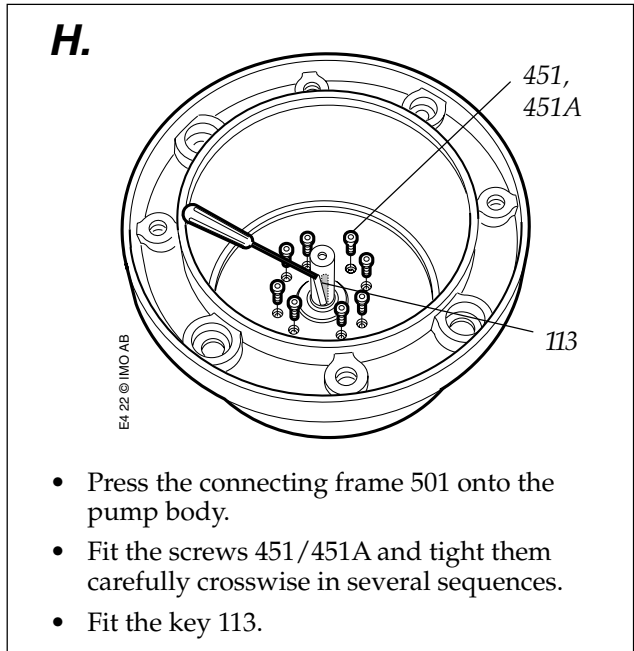

Fig. 22

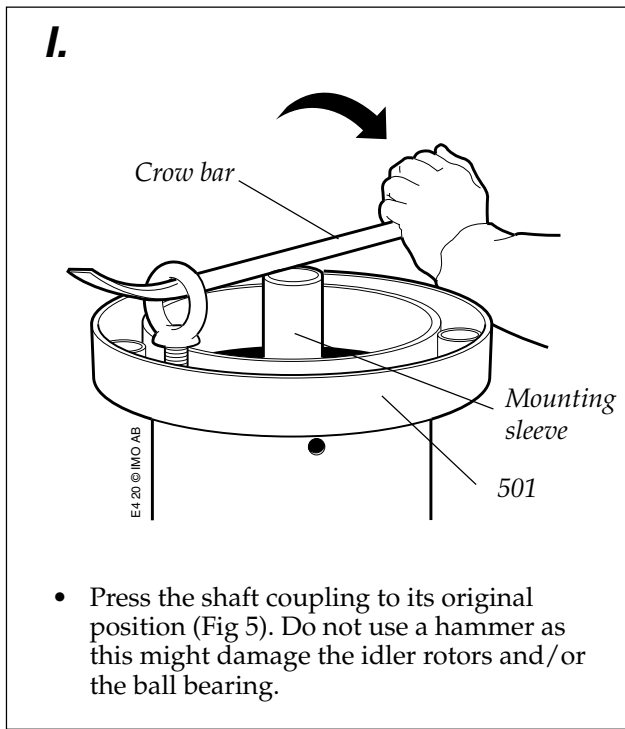

Fig. 23

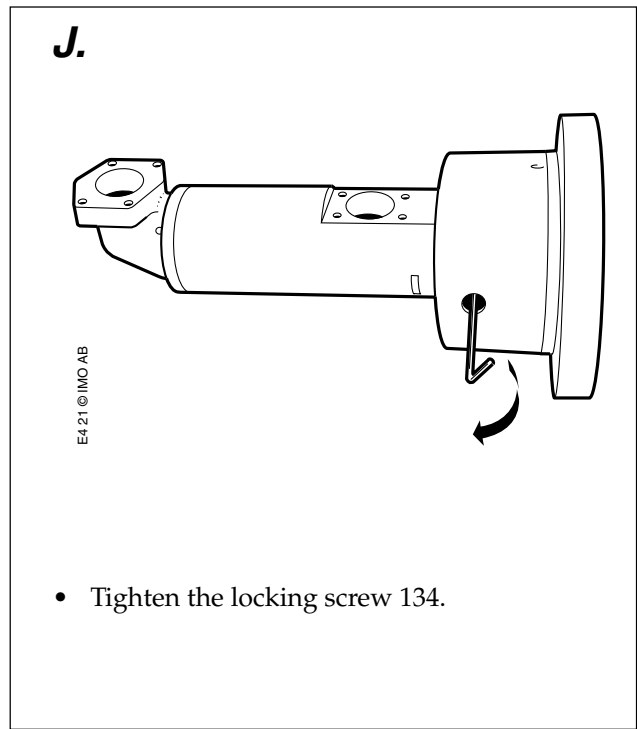

Fig. 24

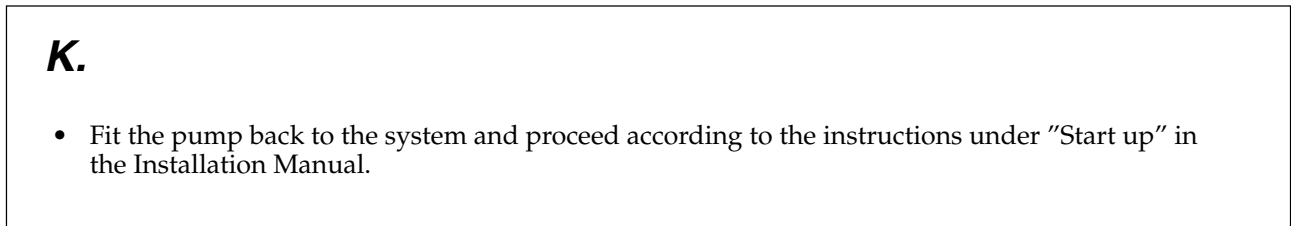

Fig. 25



A Member of the
COLFAX PUMP GROUP

www.imo.se

IMO AB:

P. O. Box 42090, SE 126 14 Stockholm, Sweden

Telephone: +46 8 50 622 800, Telefax: +46 8 645 1509