

## Maintenance and Service Instruction

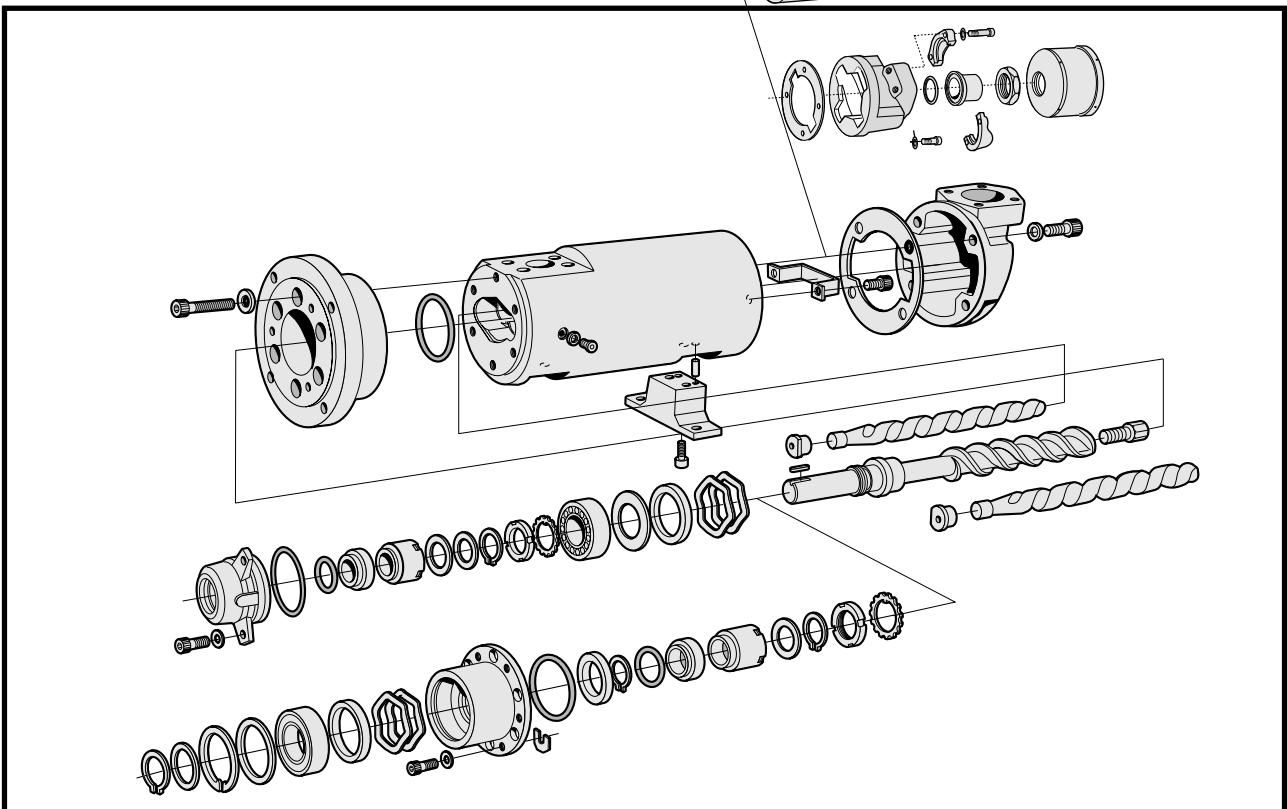

**This instruction is valid for all D6 pump models shown on page 2**

<b>Contents</b>	<b>Page</b>
List of components	2
Exploded view	3
Ordering code/Service intervals	4
Sectional view	5
Inspection of rotors	6
Useful tools/Inspection of shaft seal	6
Internal ball bearing – Dismantling/Reassembly	7
External ball bearing – Dismantling/Reassembly	12
Replacing gasket	15



Before commencing any work, read this instruction carefully! Failure to comply with these instructions may cause damage and personal injury!

For more information about the pumps identification code, technical data and performance we refer to the D6 Product description. For more information about the pumps installation, Start-up and trouble shooting we refer to the IMO Installation and Start-up instruction for medium and high pressure pumps.

## List of components

Valid for all D6 pumps in sizes 038/045/052/060/070. Rotor diameter and generation: K3/N3

With version codes:  $\left. \begin{matrix} S \\ R \\ T \\ V \end{matrix} \right\} \left. \begin{matrix} B \\ F \\ T \\ J \end{matrix} \right\} \left. \begin{matrix} Y \\ Z \end{matrix} \right\}$  The version code is composed of the letters in the 4 columns. Also valid for: Pump option A101, A309.  
*Example of pump designation std: D6 038 N3 STBZ*  
*Option: D6045K3 STBZ A101*

Pos no	Denomination	Qty	G012	G050	G053	G054	G057	Note
102	Power rotor	1	x			x		
1030	Return valve	1	x			x		
120	Distance washer	1	x		x	x	x	1
122	Ball bearing	1			x	x	x	
123	Locking washer	1			x	x	x	2
124	Bearing nut	1			x	x	x	2
124	Retaining ring	2			x	x	x	1
124A	Support ring	1			x	x	x	1
139	Balancing ring	1	x			x		
139A	Shaft nut	1	x			x		1
139B	Washer	1	x			x		1
202	Idler rotor	2	x			x		
376	Balancing bush	2	x			x		
382	Screw	4						4
391	Plate	1						4
395	Supporting plate	1						
395A	Screw	1						
401	Pump body	1						
423	O-ring	1						3
427	Split flange	2						3
427A	Pipe weld	1						3
428	Screw	4						3
428A	Washer	4						3
451	Screw	6						
451A	Washer	6						
453	Screw	4						
453A	Washer	4						
463	Plug	1						
463A	T-ring	1			x	x	x	
489	Strainer	1						3, 4
491	Nut	1						3
501	Front cover	1						
506	O-ring	1			x	x	x	
507	Support ring	1						
507A	Locking washer	1						
507B	Washer	1						2
509	Mechanical shaft seal	1		x	x	x		
514	Retaining ring	1						1
514A	Support ring	1						1
520	Cover	1				x		
520A	O-ring	1			x	x	x	
521	Screw	3						
521A	Washer	3						
521B	Shims	1						1
523	Distance washer	1						

### Explanations:

G012 = Rotor set  
CW-rotation

G050 = Shaft seal

G057 = Joint kit

### Note:

1 Valid for xxxY

2 Valid for xxxZ

3 Valid for xxJx

4 Valid for xxTx

Pos no	Denomination	Q-ty	G012	G050	G053	G054	G057	Note
523A	Spring	2						
523B	Shims	2						2
551	Inlet chamber	1						
556	Gasket	1			x	x	x	

## Exploded view

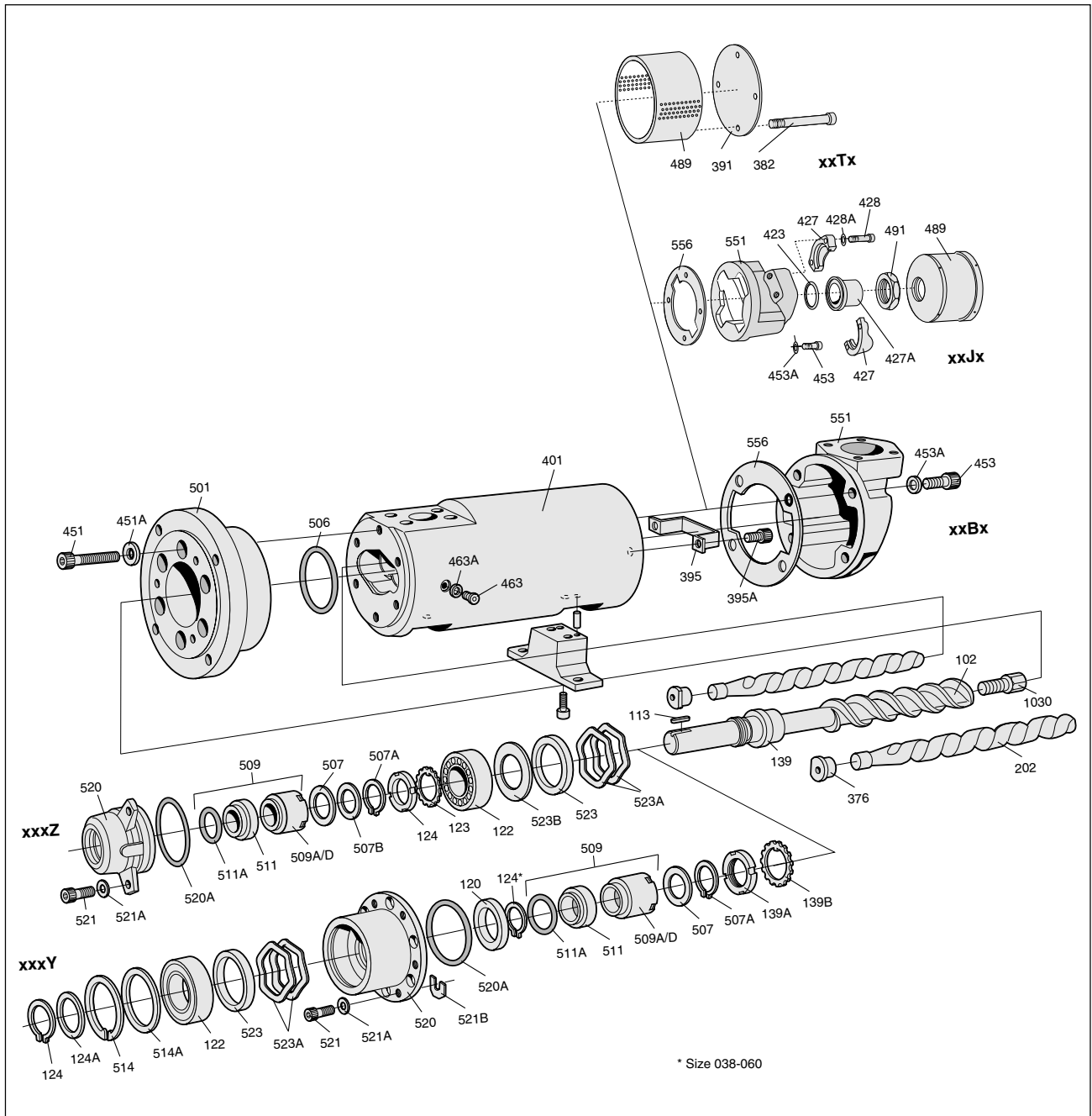

Fig.1

# Ordering code

Pos no	Spare parts sets	Part numbers, sizes				
		038	045	052	060	070
G012	N-lead/I-lead xxxZ	162958	162974	162990	163014	163030
	K-lead xxxZ	162941	162966	162982	163006	163022
	N-lead xxxY	163055	163071	163097	163113	163139
	K-lead xxxY	163048	163063	163089	163105	163121
G050	xRxZ	120873	124610	134908	128728	164921
	xTxZ	172726	172049		168914	173047
	xVxY	159988	159855	159749	159541	159467
	xTxY				189455	
	xVxZ	121780	190338	190340	142299	168211
G057	xRxZ	185959	185967	185975	185983	185991
	xVxZ	189036				189037
	xxxY	186007	186015	186023	186031	186049

## Recommendation for maintenance

Every shut down for service of a plant is costly. The time for repair should therefore be limited to a minimum which can be accomplished by keeping a spare pump. The changed pump can later be repaired at a suitable place and can then be used as a spare pump. For maintenance the following spare parts kits are recommended:

Kit	Contents	To be used for
G057	Gasket, ball bearings, etc.	Dismantling of the pump.
G053	Minor kit G057 + shaft seal G050.	Normal scheduled inspection.
G054	Major kit, pump element G102 (CW)	Repair after damage or greater wear
Ordering Example		For IMO-pump D6 038N3 STBZ
	Rotor set G012	Part no 162958
	Shaft seal G050	Part no 172726

## Service intervals

The intervals for inspection and replacement of wear parts vary greatly with the properties of the pumped liquid and can only be determined by experience. All internal parts of the D6-pump are lubricated by the pumped liquid. Pumping a liquid containing abrasive materials, or a liquid that is corrosive, will significantly reduce service life and call for shorter service intervals.

Wear in the pump may be indicated by:

- Vibration
- Noise
- Loss of capacity
- Reduction in flow or pressure
- Leakage

In installations where unplanned shut downs must be avoided, it is advisable to have a complete pump available for replacement, should any malfunction occur. Furthermore we recommend planned inspection and overhaul at regular intervals, not exceeding 3 years.

It is recommended always to have the spares included in the minor spare part kit available.









-  Before any maintenance work, ensure that the driver is deenergized and the pump hydraulically isolated.
-  Connecting and disconnecting of electric cables must be done only by personnel authorized to do such work.

Fig. 2

-  If the operating temperature exceeds 60°C let the pump cool off before any service, maintenance or dismantling work is commenced to avoid burn injury.
-  All work carried out on the pump has to be performed in such a manner that risks for personal injury are observed!
-  When handling liquids that may harm skin use gloves and/or protective clothing.
-  When handling liquids which may involve fire hazards appropriate precautions to avoid danger are to be taken.
-  In case of failure for a system with elevated pressure, fluid jets may cause injury and/or damage.
-  Oil leakage may make the floor slippery and cause personal injury.

# Sectional view

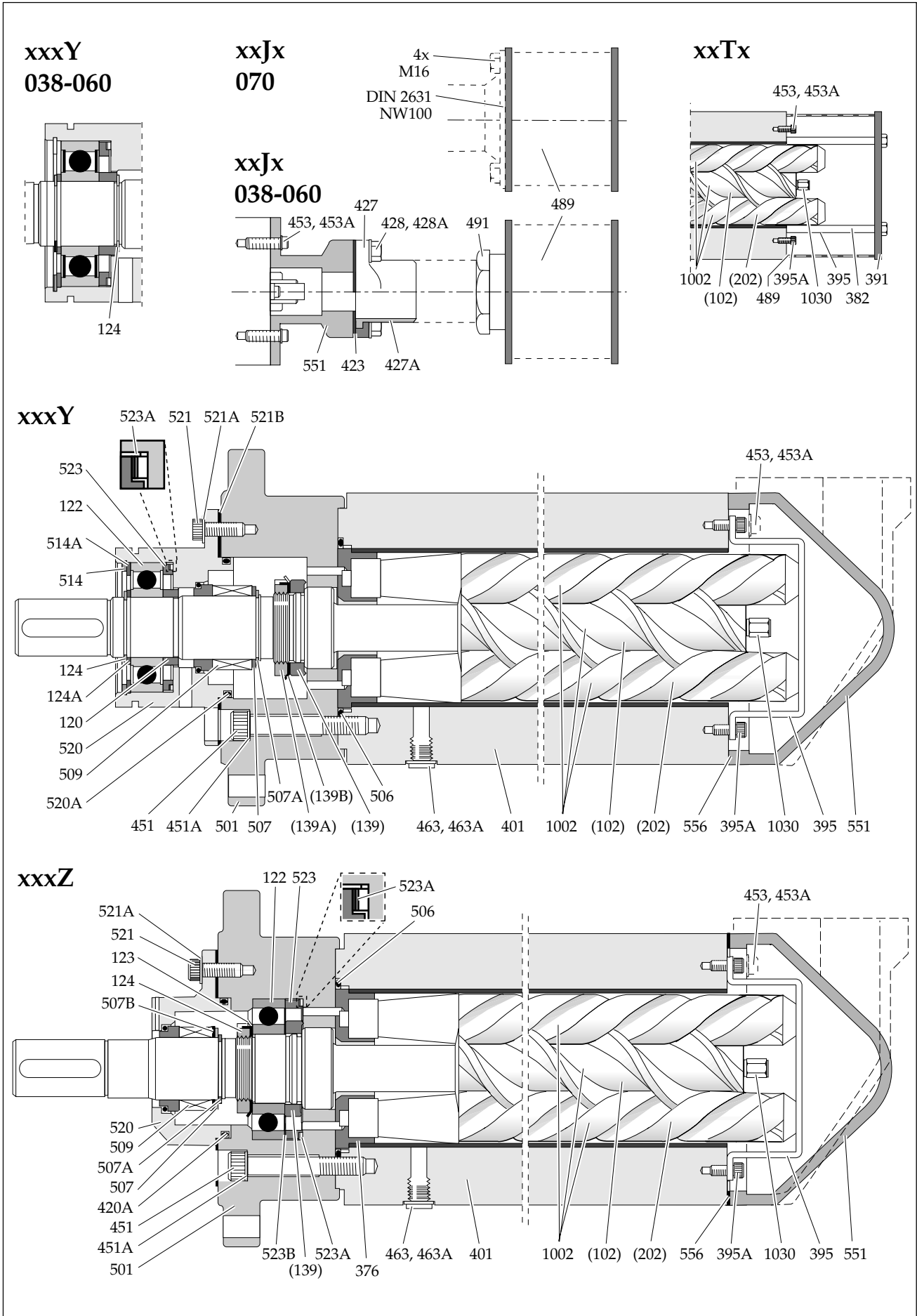

Fig. 3

## Inspection of rotors

If the pump is not able to maintain the pressure inspect the rotor parts by following the instructions in fig. 13.

Acceptable clearances can be determined only by experience of the actual application. As a rule of thumb the following values may apply:

- Between rotor and bores or bushings: 0.2 mm
- Between rotor flanks: 0.2 mm

For light duties (low pressure, medium viscosity) even bigger clearances may be acceptable but for low visc./high pressure duties the limit will be lower. Also watch if there are major scratches on these parts.

## Useful tools

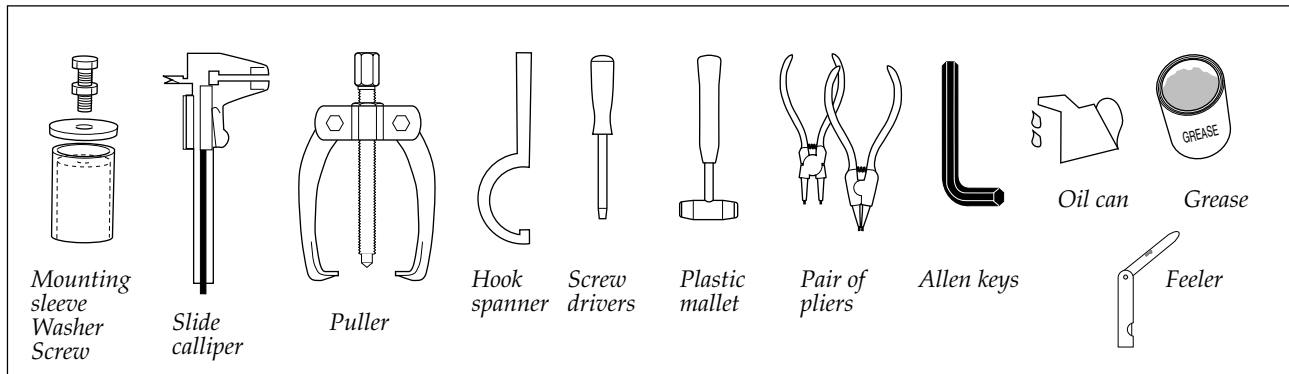

Fig. 4

## Inspection of shaft seal

As the seal faces of a mechanical shaft seal are lubricated by the fluid, a certain leakage will always be present. Up to ten drops per hour can be considered as acceptable.

An external visual inspection of the pump is advisable at least every two days to assure that the shaft seal is not leaking too much. Excessively leaking shaft seals should be changed without delay, as the leakage normally will grow worse and cause additional damage.

Follow the instructions in the dismantling/mounting session.

When working with a shaft seal, cleanliness is of utmost importance. Avoid touching the seal faces. If necessary, the seal faces should be cleaned immediately prior to assembly, using a dustfree cloth and clean solvent.

Never use grease on the seal faces.

## Shaft seal – assembly drawing

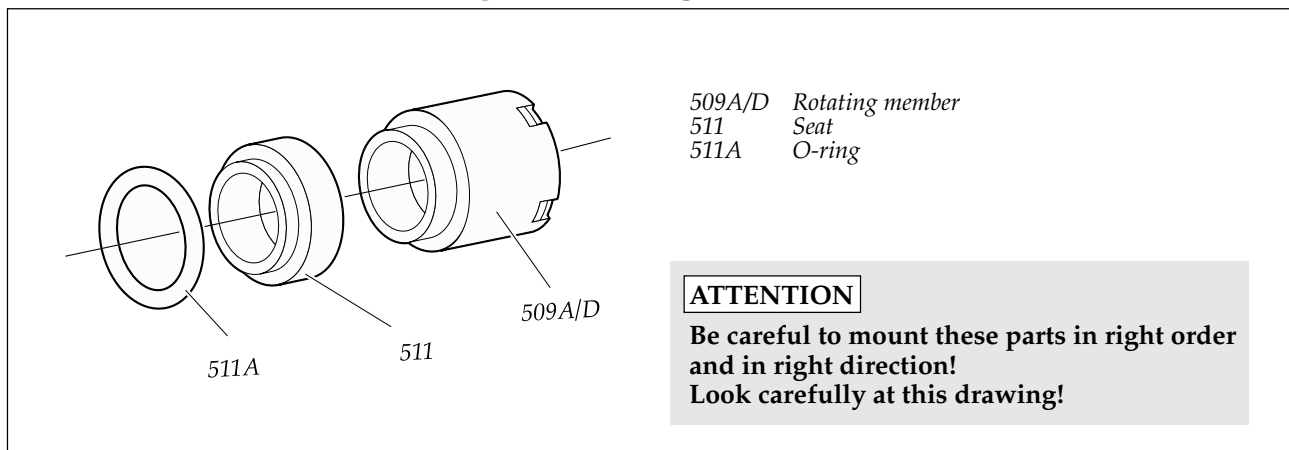

Fig. 5

## Internal ball bearing – Dismantling

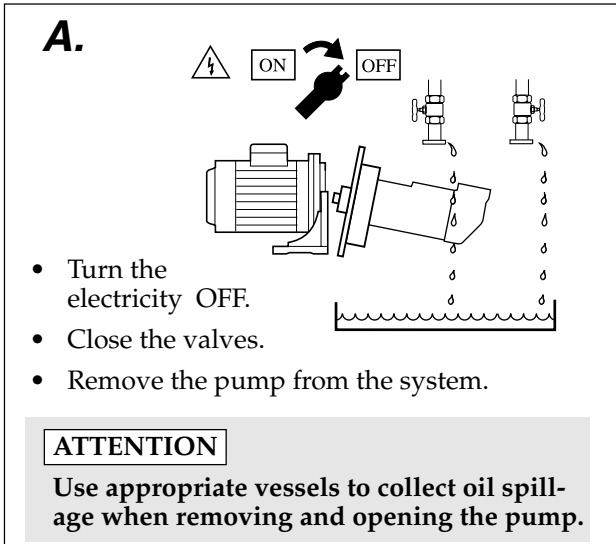

Fig. 6

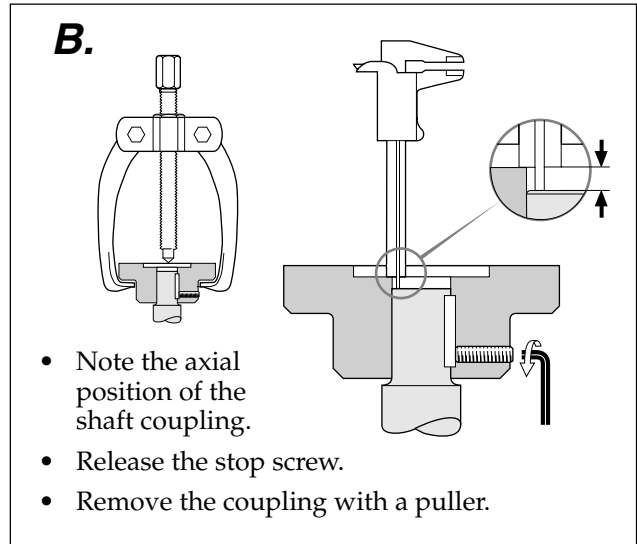

Fig. 7

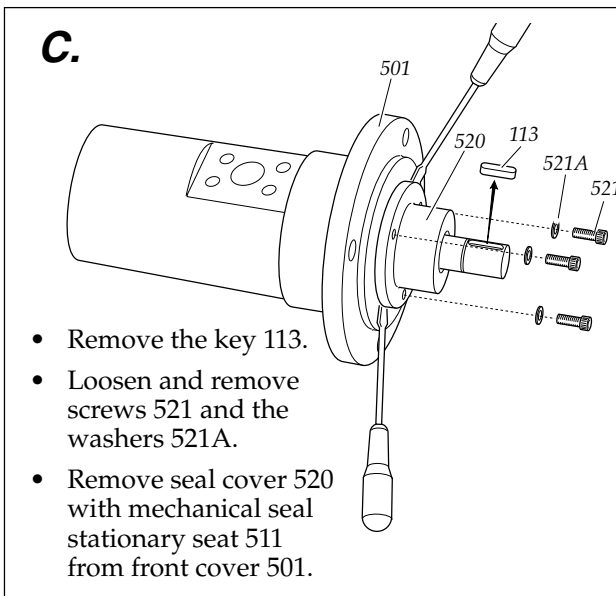

Fig. 8

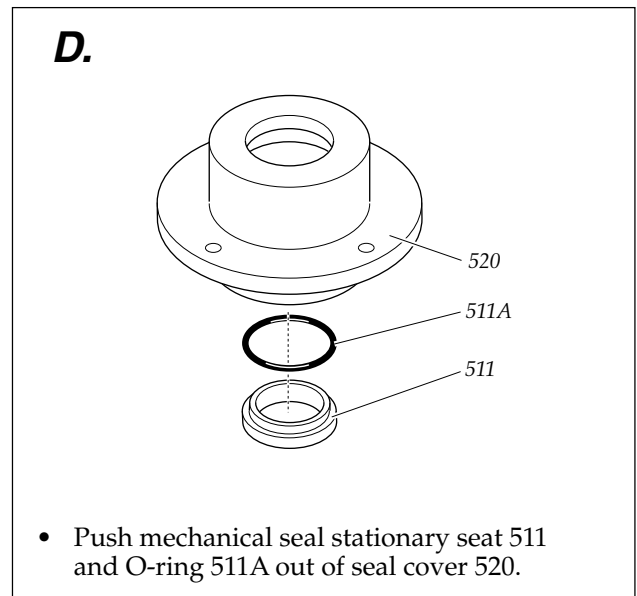

Fig. 9

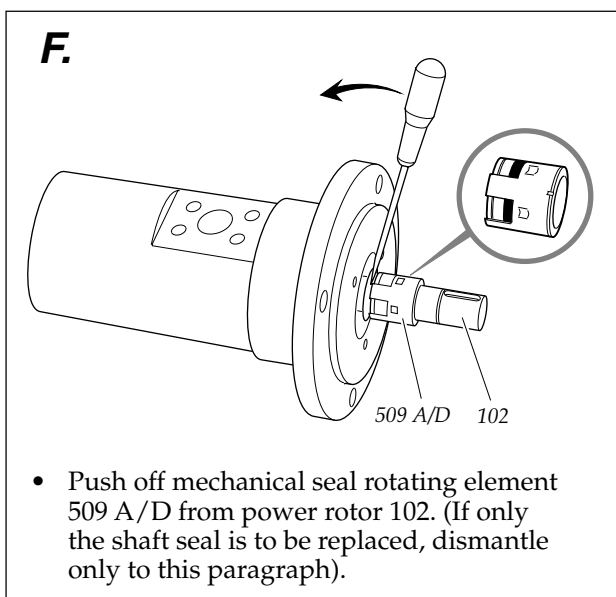

Fig. 10

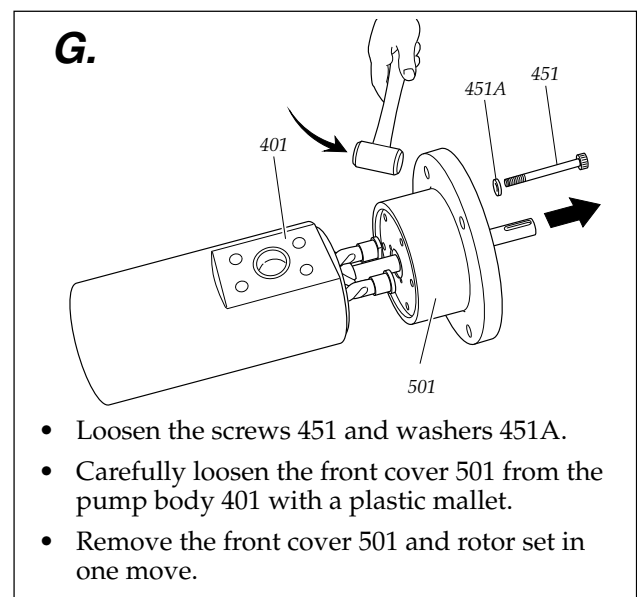

Fig. 11

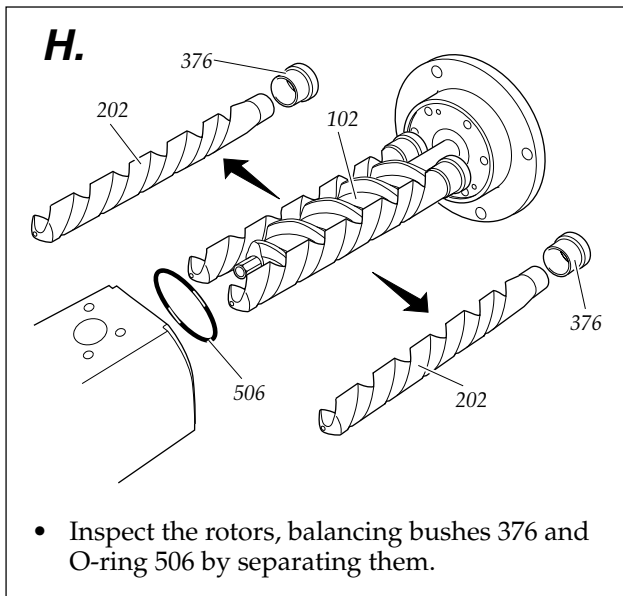

Fig. 12

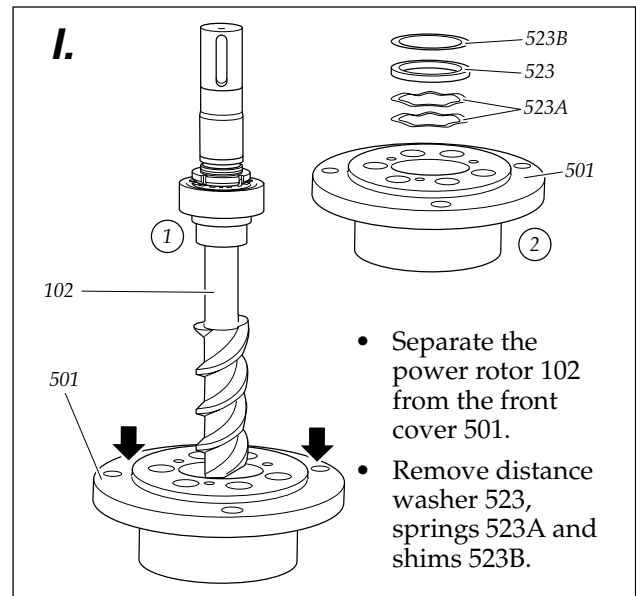

Fig. 13

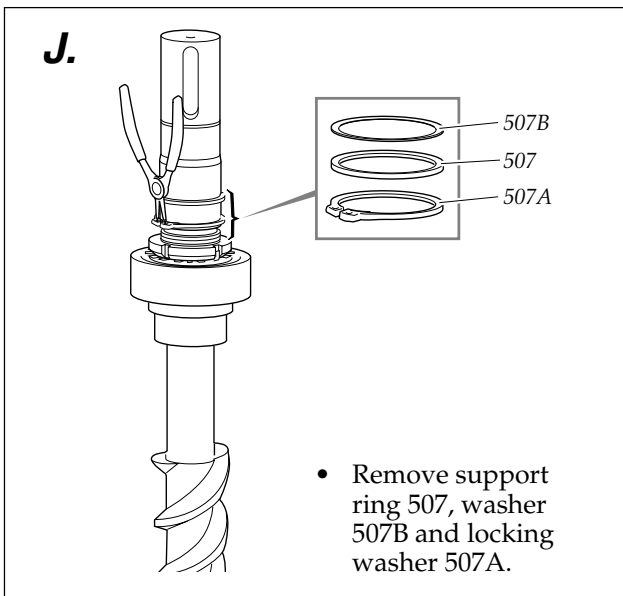

Fig. 14

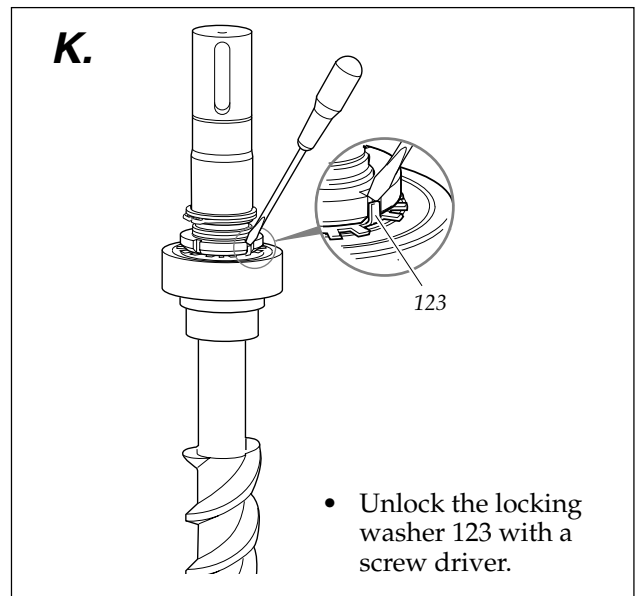

Fig. 15

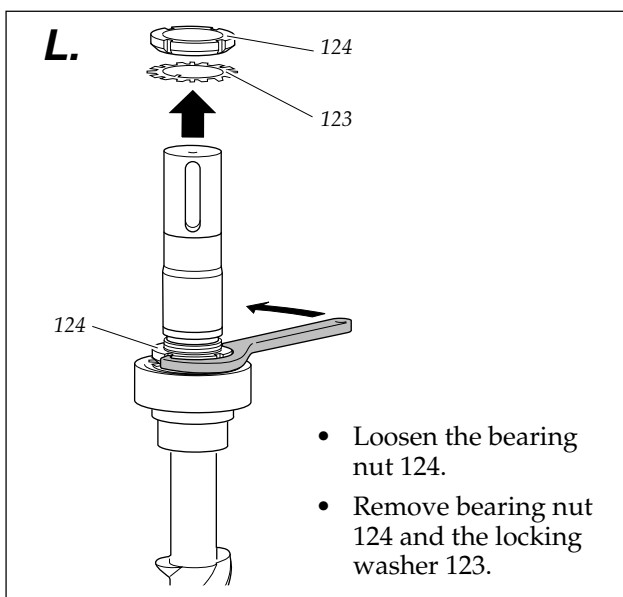

Fig. 16

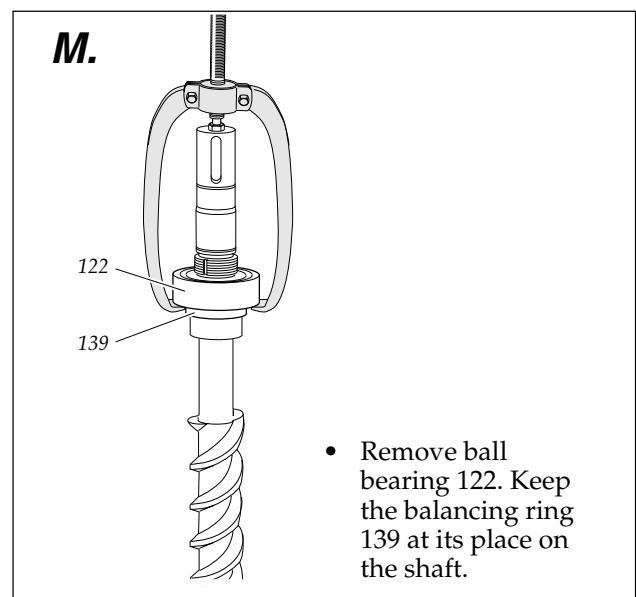

Fig. 17



## Reassembly

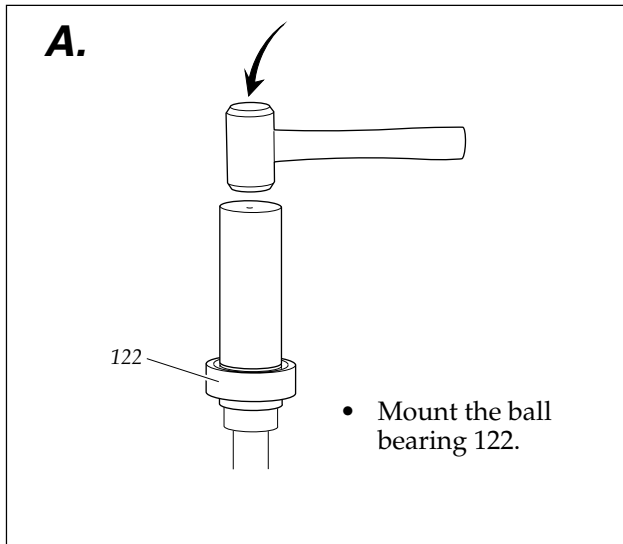

Fig. 1

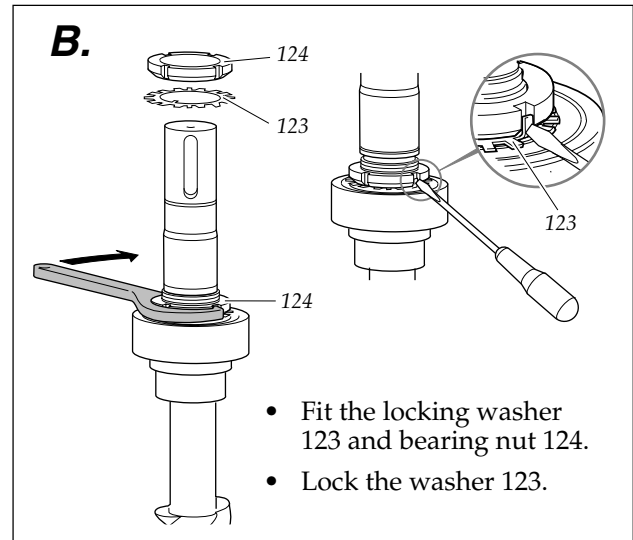

Fig. 19

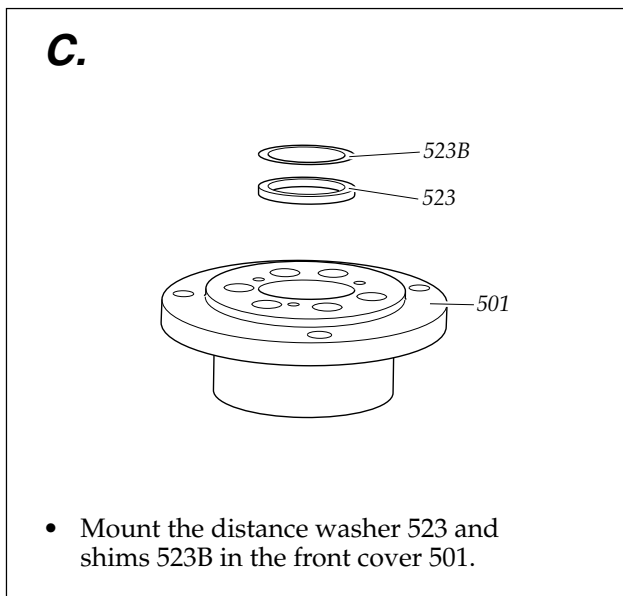

Fig. 20

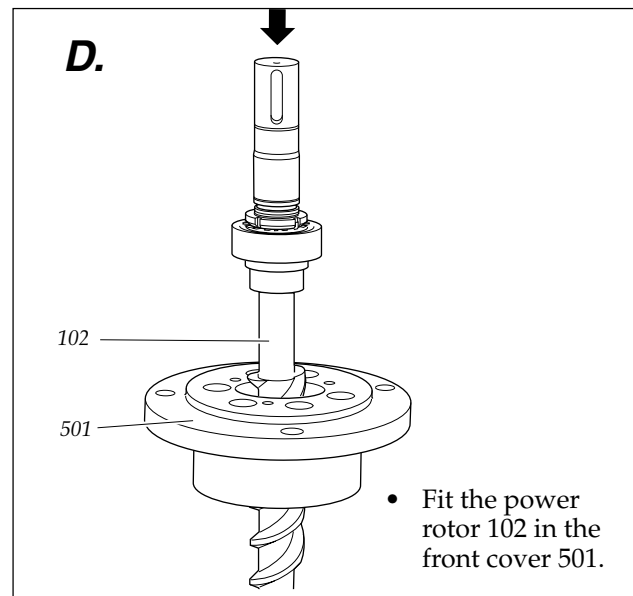

Fig. 21

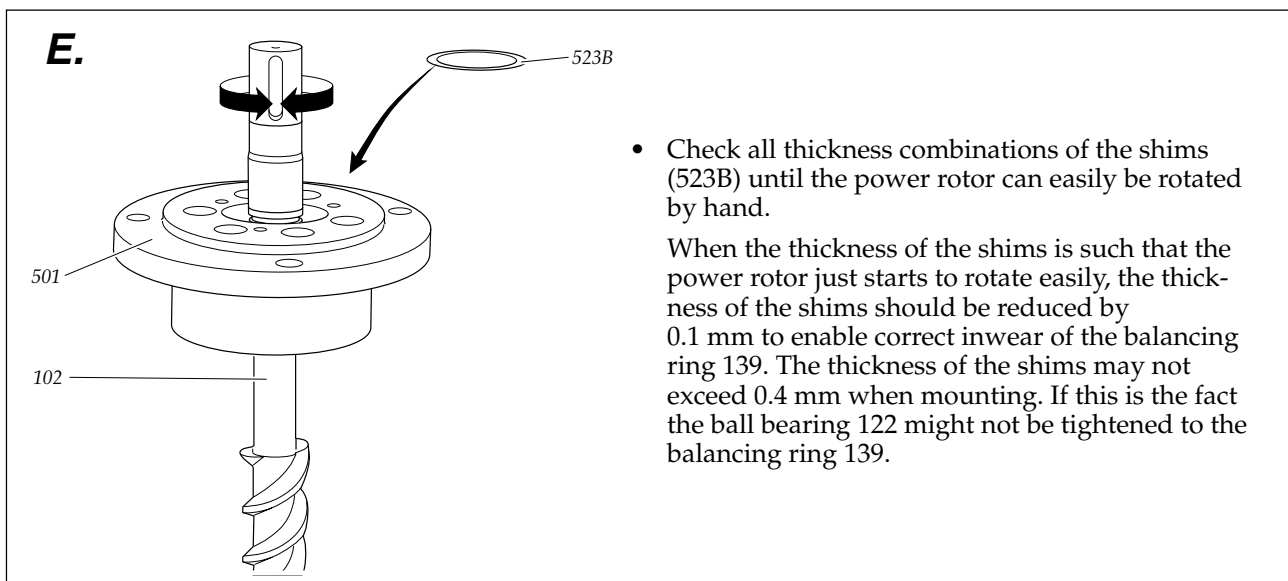

Fig. 22

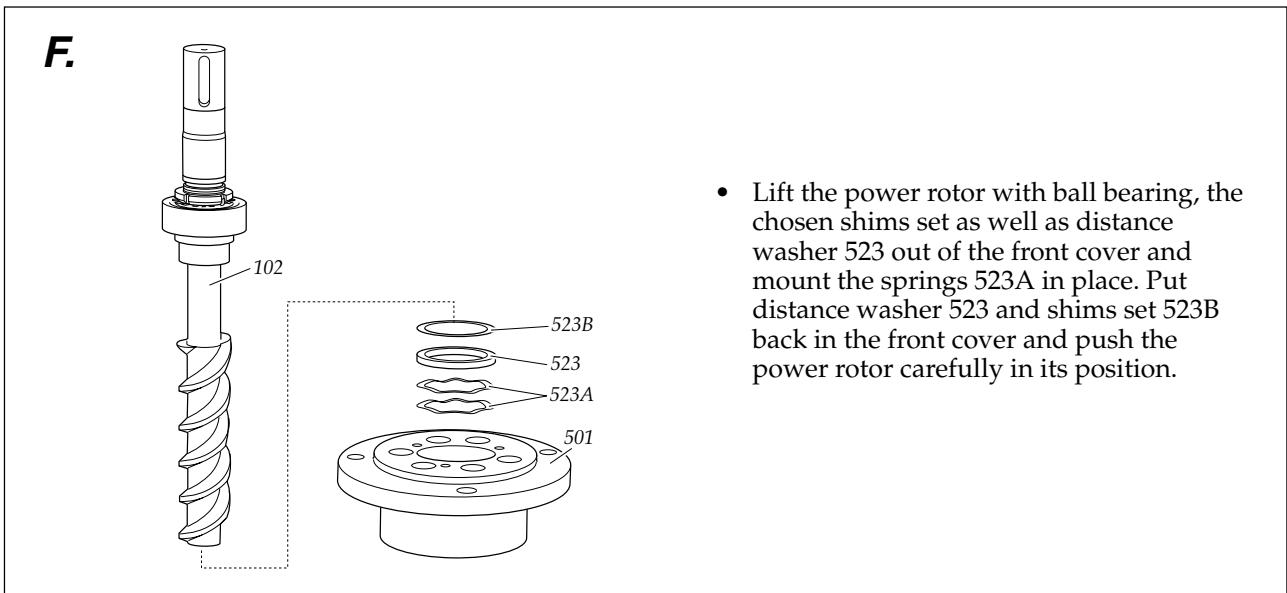

Fig. 23

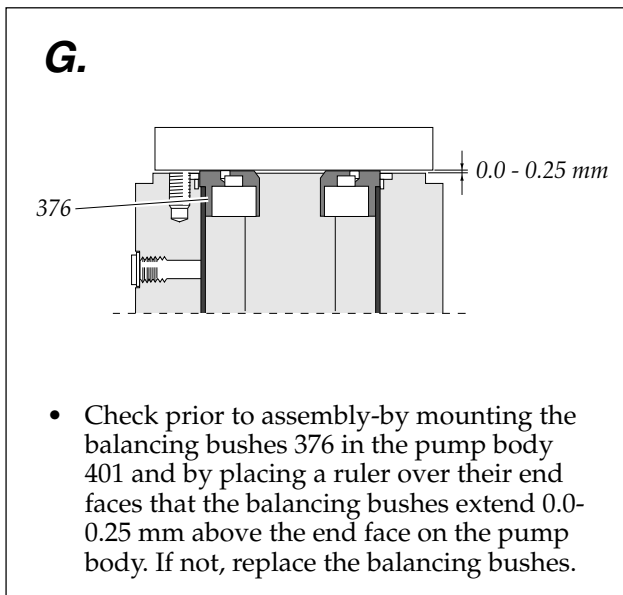

Fig. 24

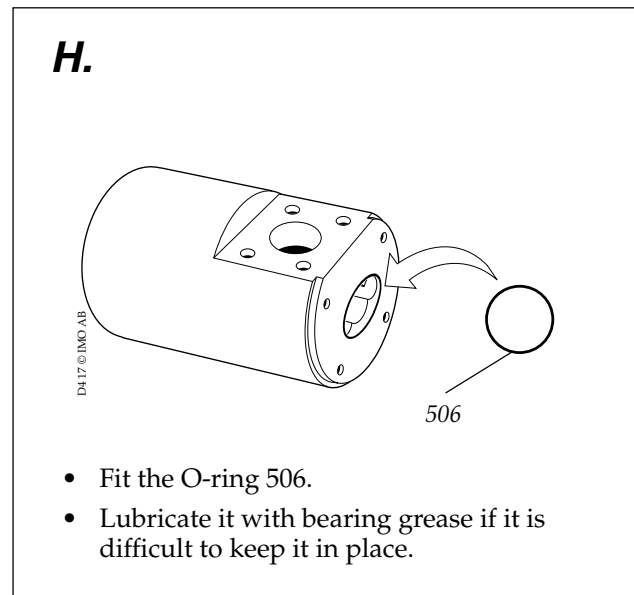

Fig. 25

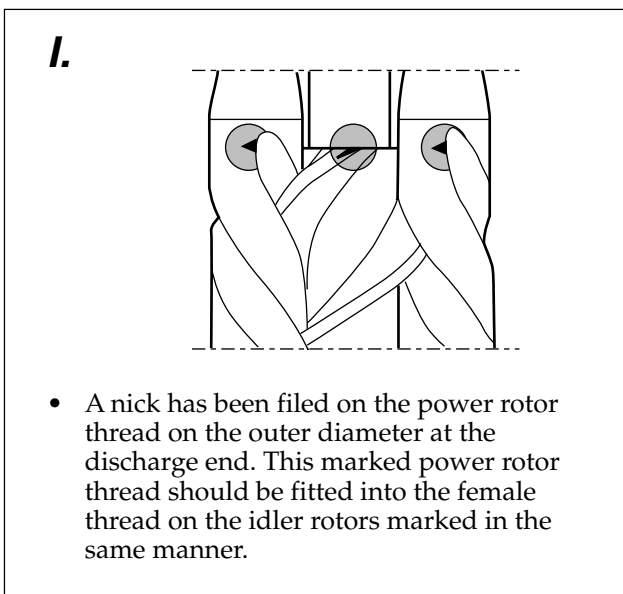

Fig. 26

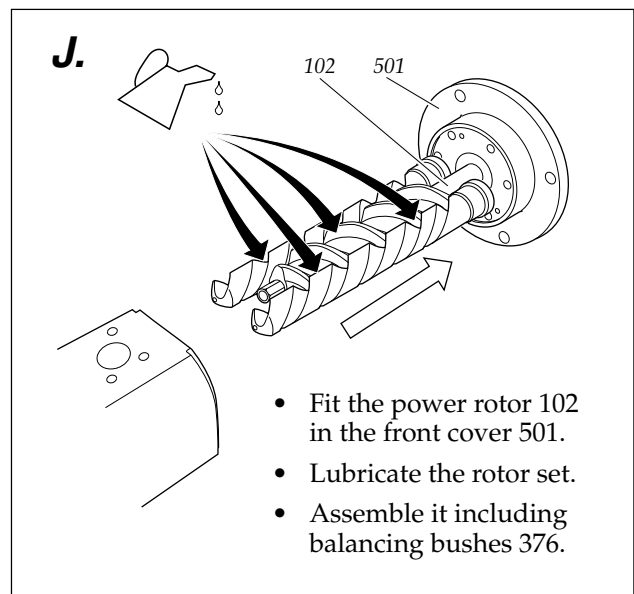

Fig. 27

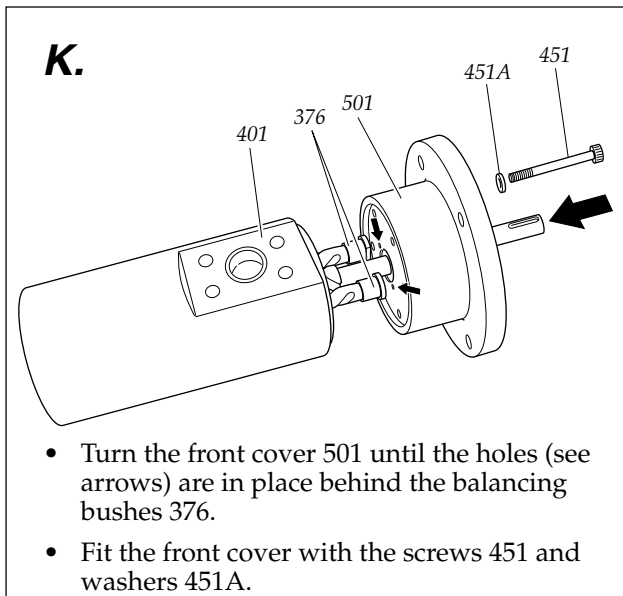

Fig. 28

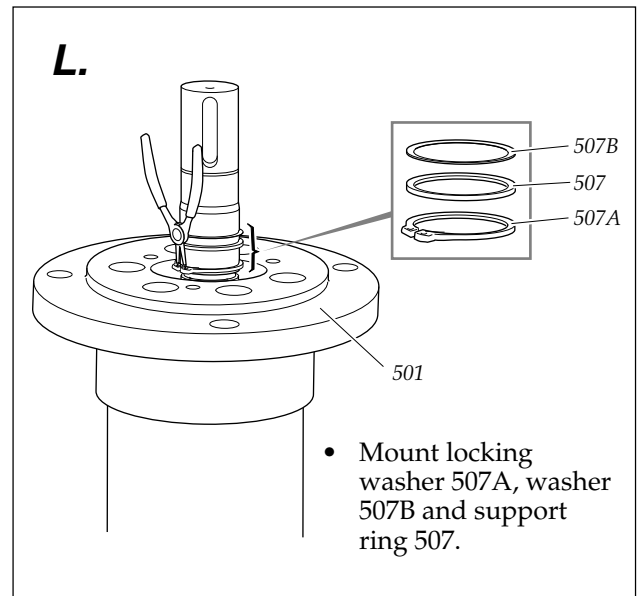

Fig. 29

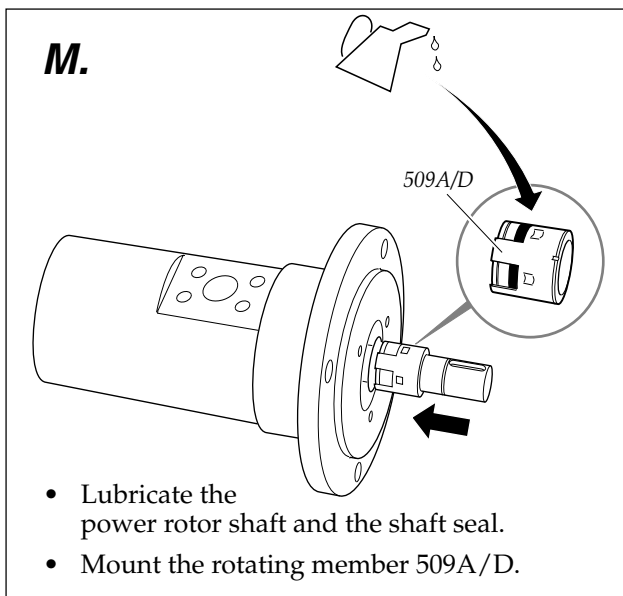

Fig. 30

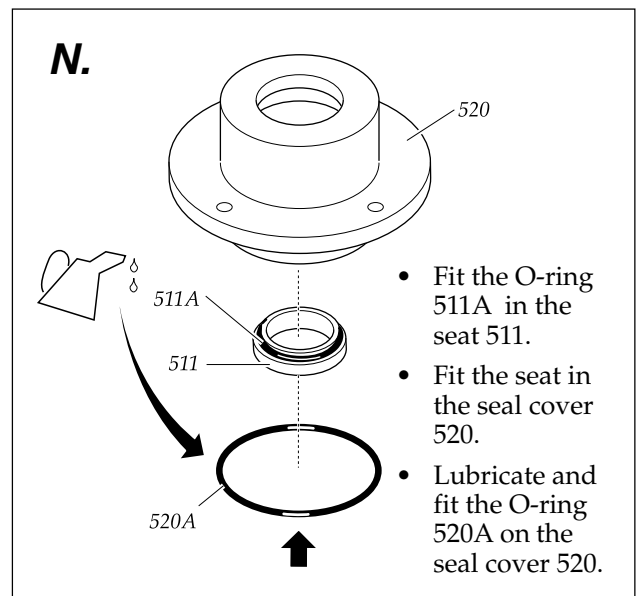

Fig. 31

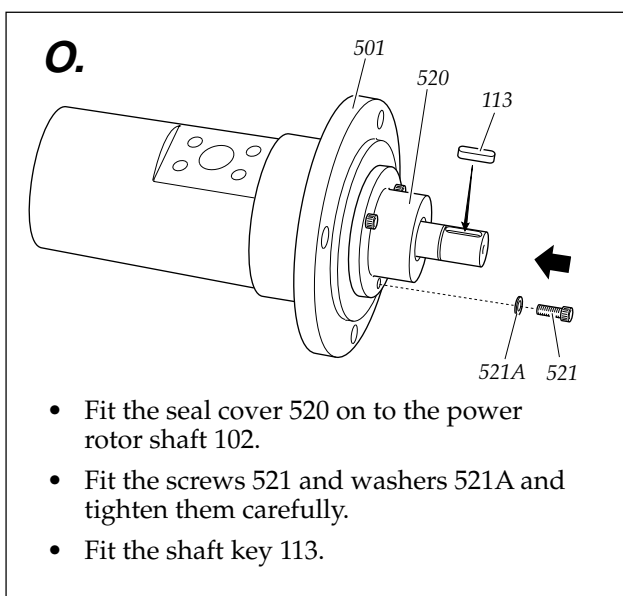

Fig. 32

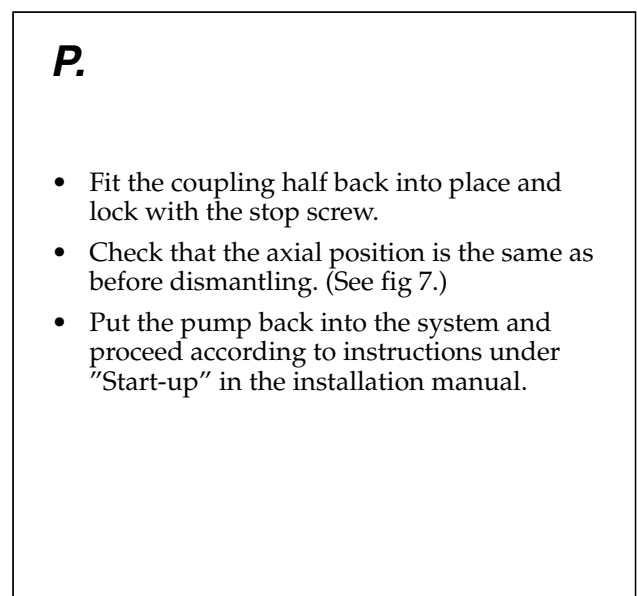

Fig. 33

## External ball bearing – Dismantling

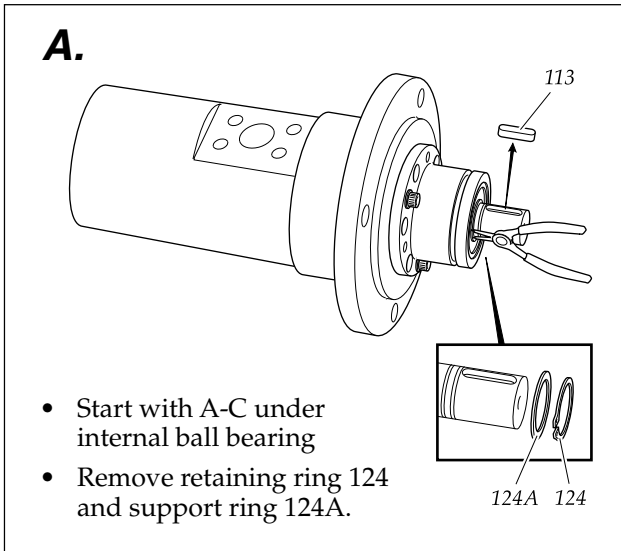

Fig. 354

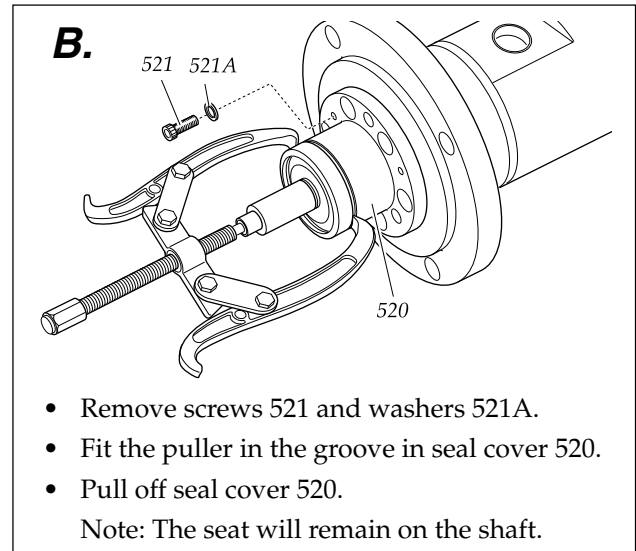

Fig. 365

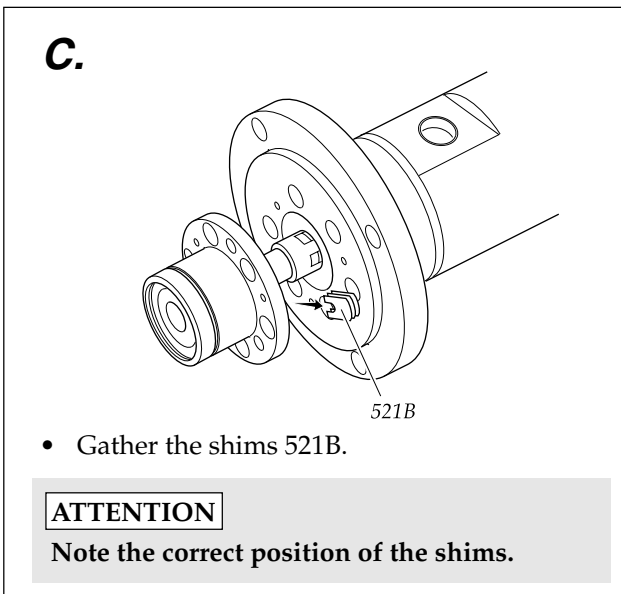

Fig. 36

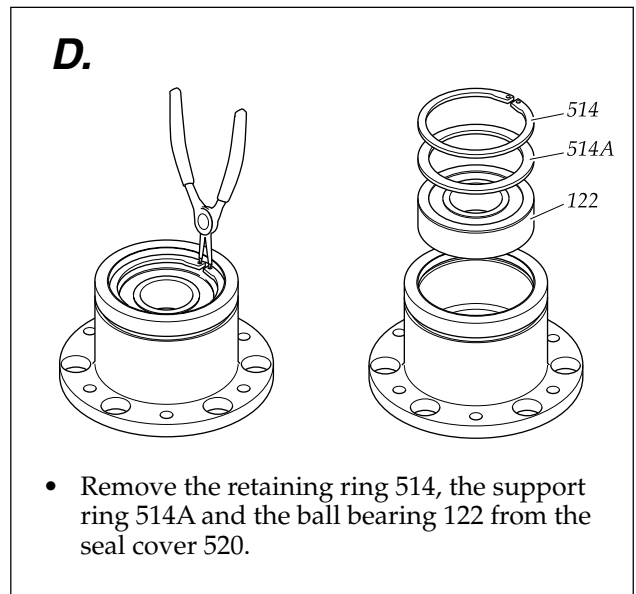

Fig. 37

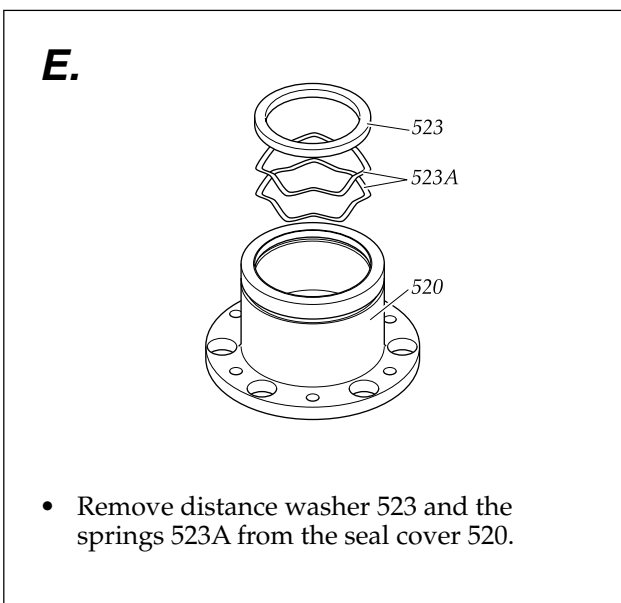

Fig. 38

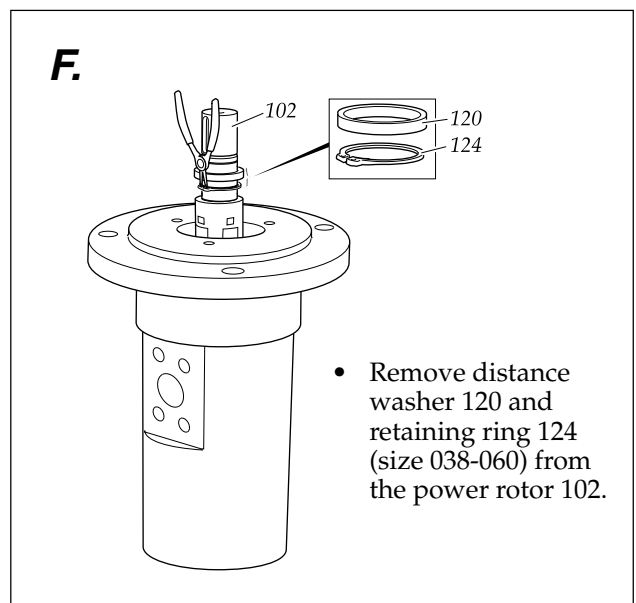

Fig. 39

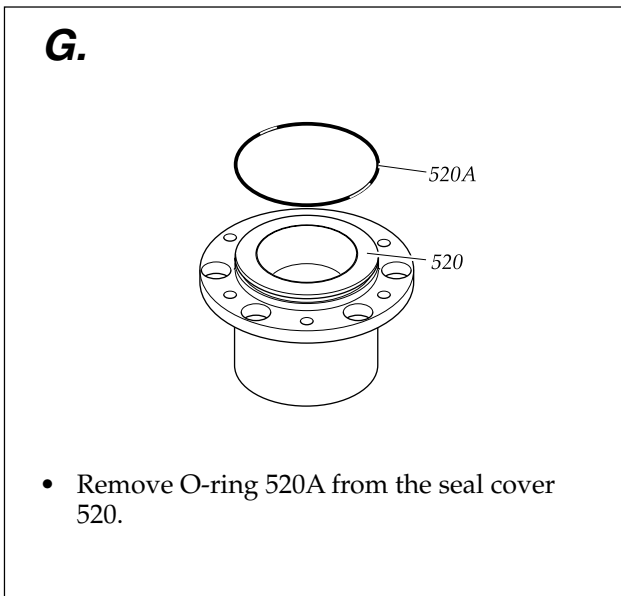

Fig. 40

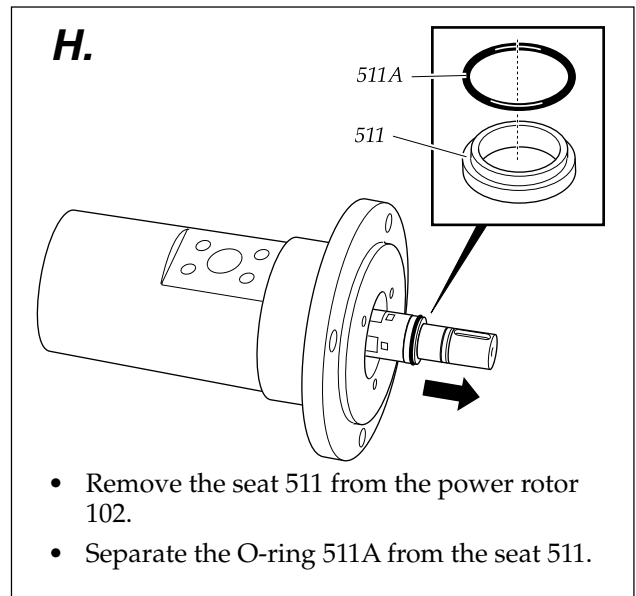

Fig. 41

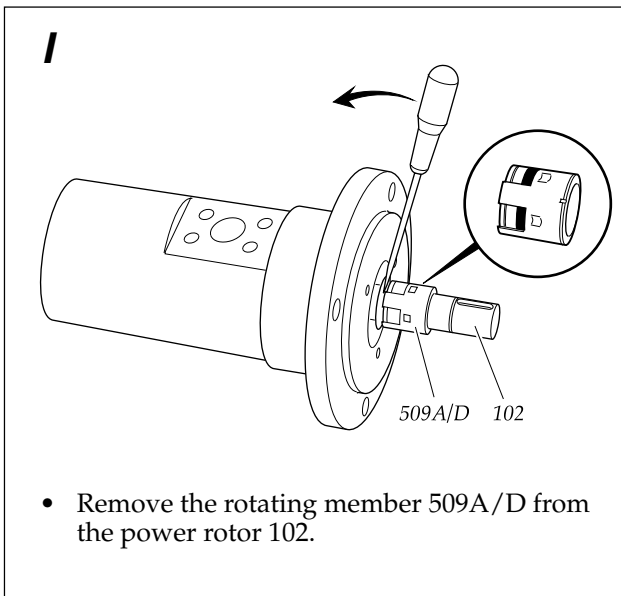

Fig. 42

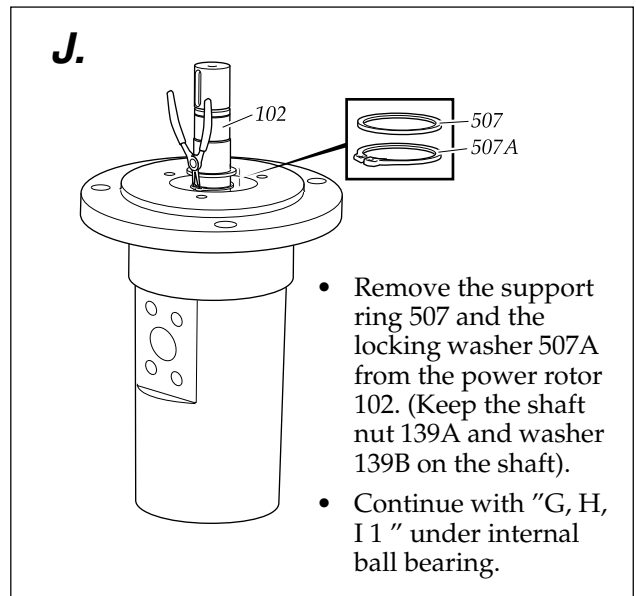

Fig. 43

## Reassembly

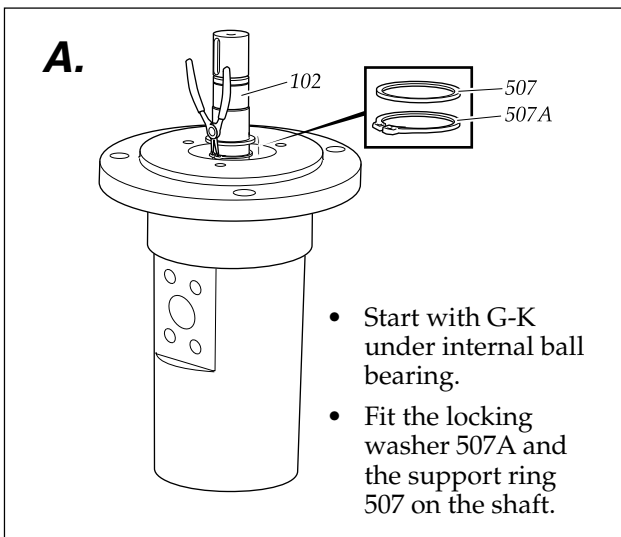

Fig. 44

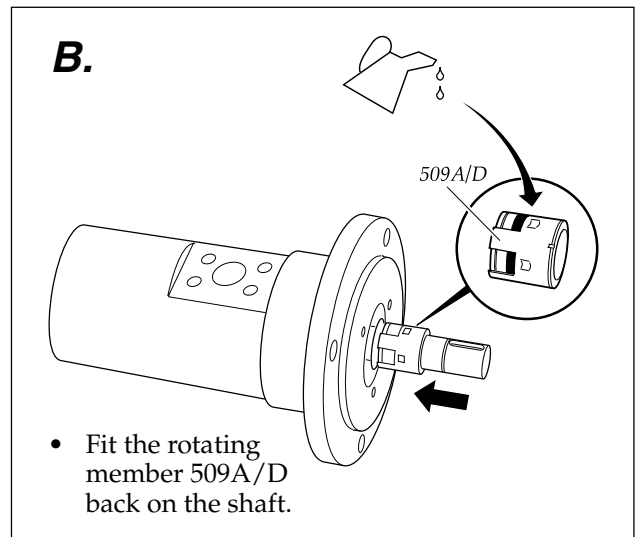

Fig. 45

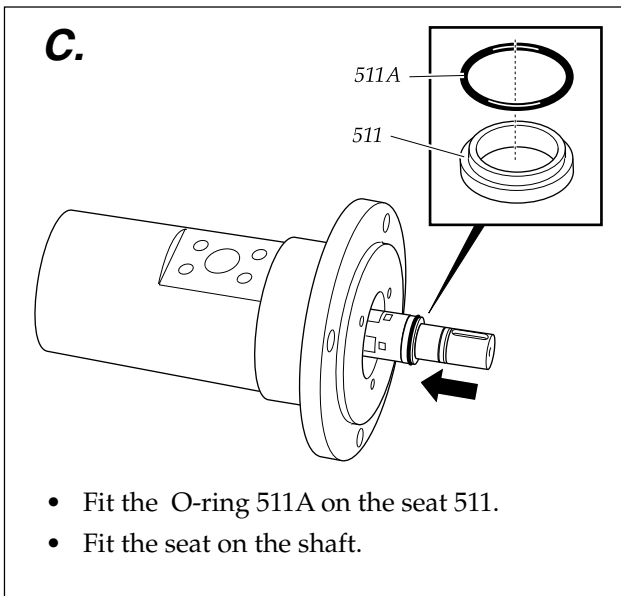

Fig. 46

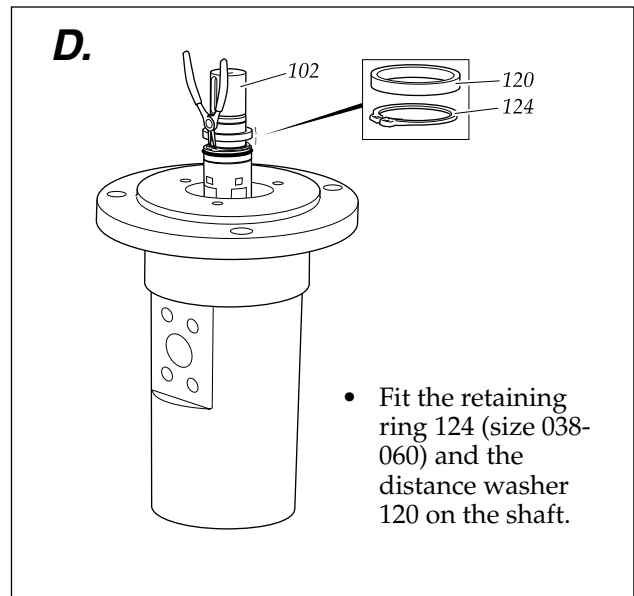

Fig. 47

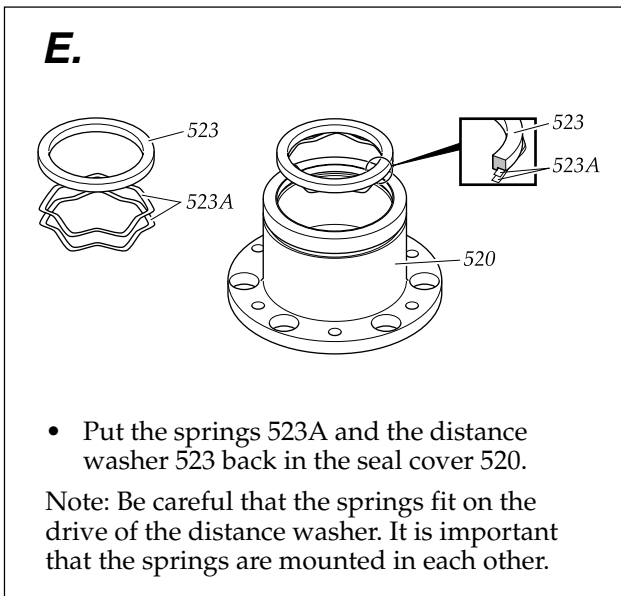

Fig. 48

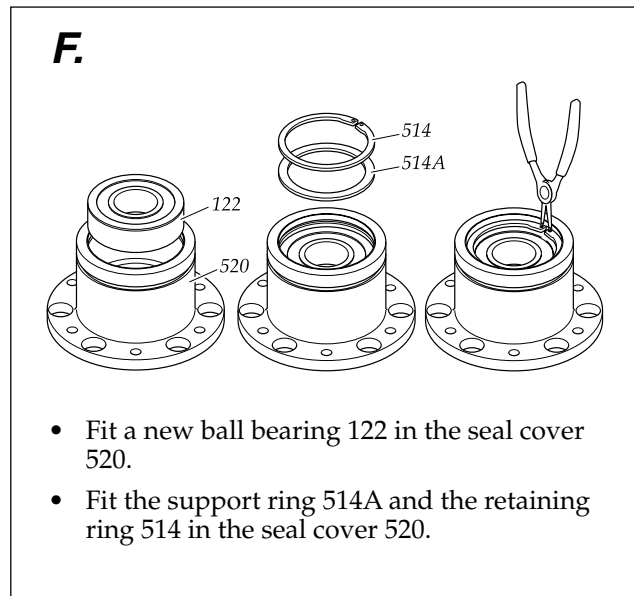

Fig. 49

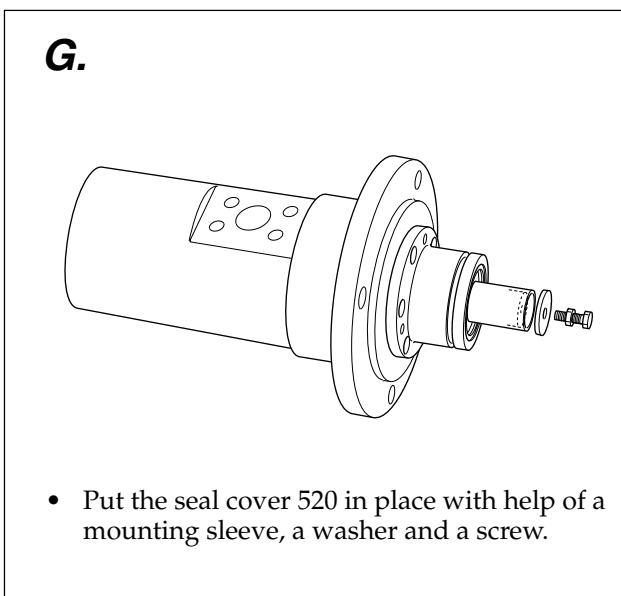

Fig. 50

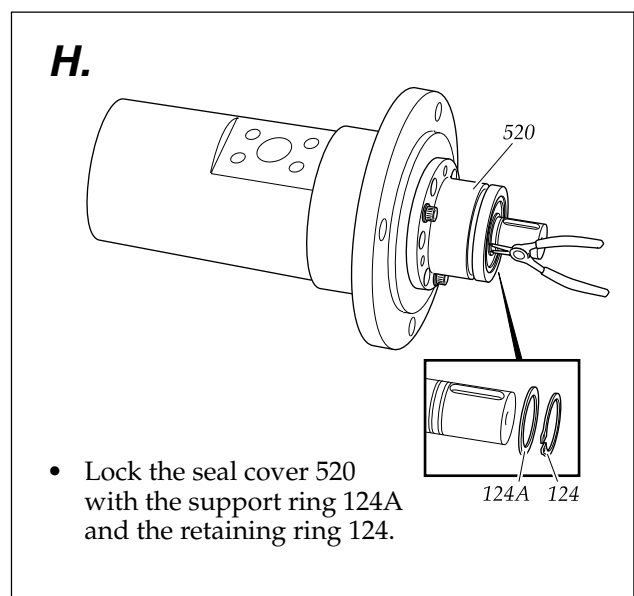
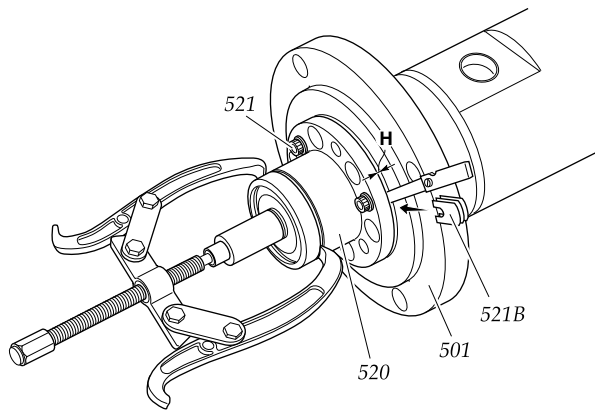

Fig. 51

**I.**



- Use a puller to eliminate clearance in ball bearing and the spring flexibility.
- Measure the clearance H between seal cover (520) and front cover (501) using a feeler. Measurements to be made at the three screws (521). Use the average figure of the three measurements and choose from shims table the suitable combination of shims set (521B).
- Put shims around each of the screws (521) between the cover (520) and front cover (501). Take away the puller and tighten the screws (521).
- Check that the shaft can be turned.

N.B. The shaft seal gives a certain turning resistance which is quite normal.

Check before and after tightening that the shaft can be turned.

Fig. 52

Measured average figure H(mm)		Tot. thickness shims to mount (mm)	Thickness combination to be chosen (mm)
from	to		
0	0.04	Support ring to be surface ground to 0.1 mm	
0.04	0.14	0	
0.14	0.24	0.1	0.1
0.24	0.34	0.2	0.2
0.34	0.44	0.3	0.1-0.2
0.44	0.54	0.4	0.2-0.2
0.54	0.64	0.5	0.5 alt.0.2-0.2-0.1
0.64	0.74	0.6	0.5-0.1
0.74	0.84	0.7	0.2-0.5
0.84	0.94	0.8	0.1-0.2-0.5
0.94	1.04	0.9	0.2-0.2-0.5
1.04	1.14	1.0	0.5-0.5
1.14	1.24	1.1	0.5-0.5-0.1
1.24	1.34	1.2	0.2-0.5-0.5

Shims table

**J.**

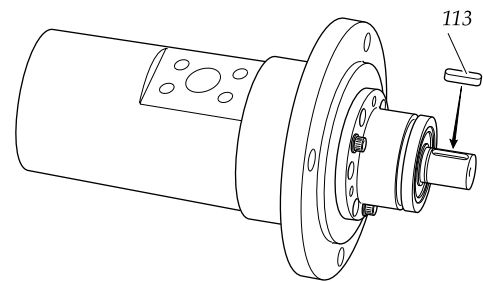

- Fit the shaft key 113 and end up with "P" under internal ball bearing.

Fig. 53

## Replacing gasket 556

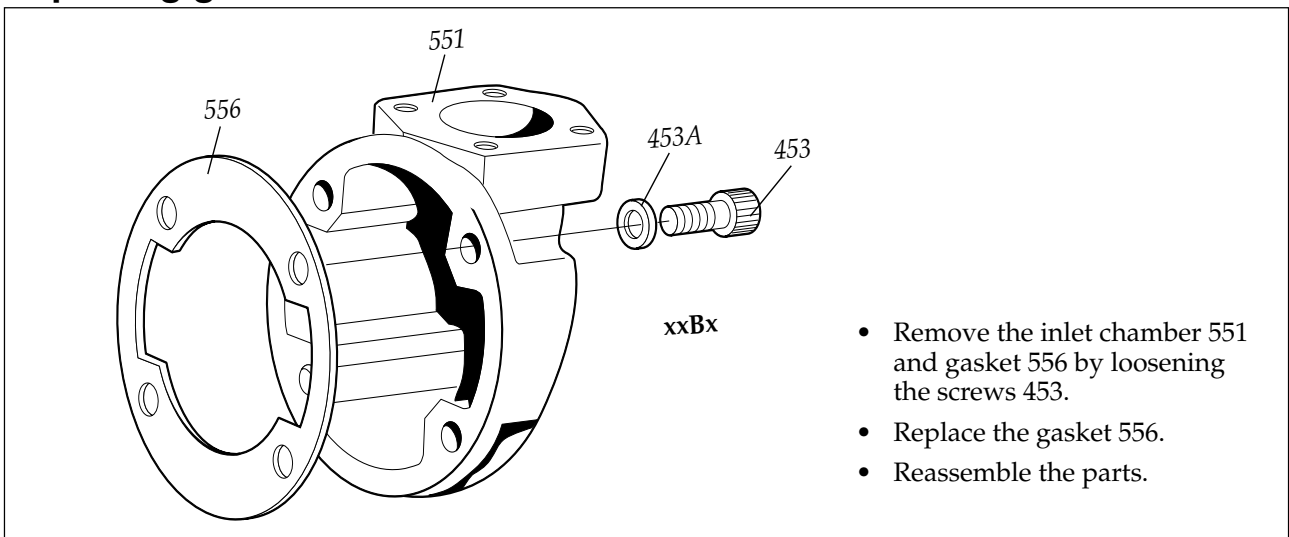

- Remove the inlet chamber 551 and gasket 556 by loosening the screws 453.
- Replace the gasket 556.
- Reassemble the parts.

Fig. 54



A Member of the  
COLFAX PUMP GROUP

**[www.imo.se](http://www.imo.se)**

---

**IMO AB:**

P. O. Box 42090, SE 126 14 Stockholm, Sweden

Telephone: +46 8 50 622 800, Telefax: +46 8 645 1509